

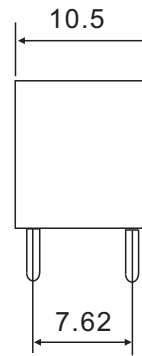

## DIMENSIONS(±0.2mm)

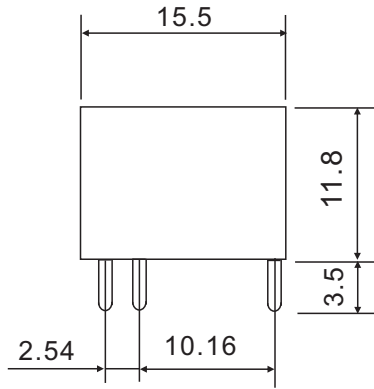

P.C.B LAYOUT  
(BOTTOM VIEW)

WIRING DIAGRAM  
(BOTTOM VIEW)

LU

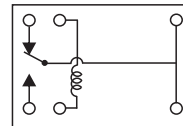
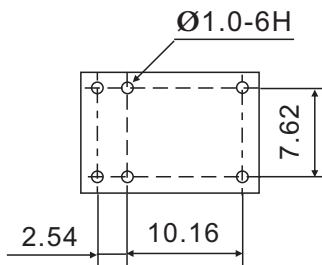

LUZ

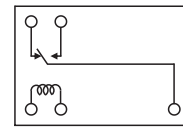
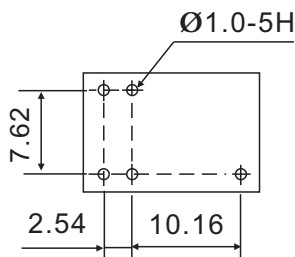

## GENERAL DATA

Insulation Resistance	100 MΩ Min. (DC 500V)
Dielectric Strength	500 VAC, 50/60Hz between contact.
	1000 VAC, 50/60Hz between all elements.
Contact Material	Ag Alloy.
Contact Resistance	100 milliohms max. ( initial value )
Shock Resistance	Malfunction: 10G(11ms) ; Destructive: 100G(6ms)
Vibration Resistance	Malfunction: 10 to 55 Hz. at Double Amplitude of 1.5 mm
	Destructive: 10 to 55 Hz. at Double Amplitude of 1.5 mm
Operation Time	5 ms max.
Release Time	5 ms max.
Temperature Range	- 30°C ~ +70°C
Expected Life	With operation rate 30/min.
	Mechanical - 10,000,000 operations min.
	Electrical - 100,000 operations min. at rated load.
Weight	4 grams



## DIMENSIONS(±0.2mm)

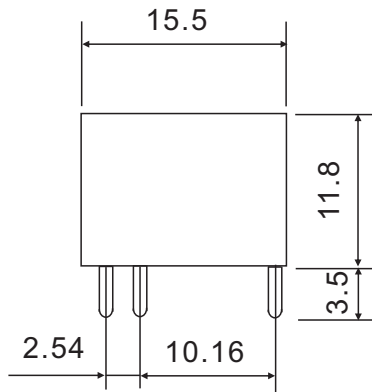

P.C.B LAYOUT  
(BOTTOM VIEW)

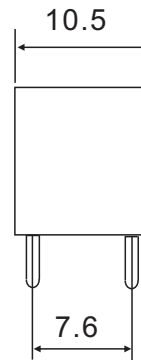

WIRING DIAGRAM  
(BOTTOM VIEW)

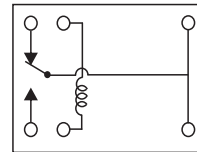
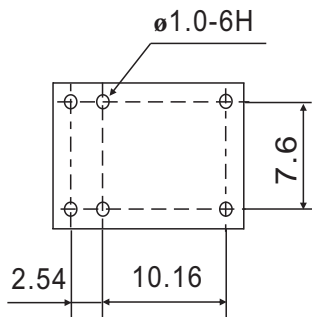

## GENERAL DATA

Insulation Resistance	100 MΩ Min. (DC 500V)
Dielectric Strength	500 VAC, 50/60Hz between contact.
	500 VAC, 50/60Hz between all elements.
Contact Material	Ag Alloy.
Contact Resistance	100 milliohms max. ( initial value )
Shock Resistance	Malfunction: 10G(11ms) ; Destructive: 100G(6ms)
Vibration Resistance	Malfunction: 10 to 55 Hz. at Double Amplitude of 1.5 mm
	Destructive: 10 to 55 Hz. at Double Amplitude of 1.5 mm
Operation Time	5 ms max.
Release Time	5 ms max.
Temperature Range	-30°C ~ + 70°C
Expected Life	With operation rate 30/min.
	Mechanical - 10,000,000 operations min.
	Electrical - 50,000 operations min. at rated load.
Weight	4 grams



## DIMENSIONS(±0.2mm)

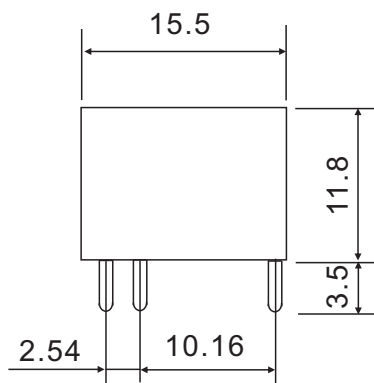

P.C.B LAYOUT  
(BOTTOM VIEW)

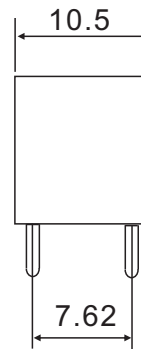

WIRING DIAGRAM  
(BOTTOM VIEW)

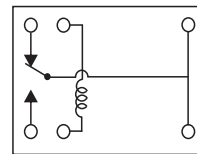
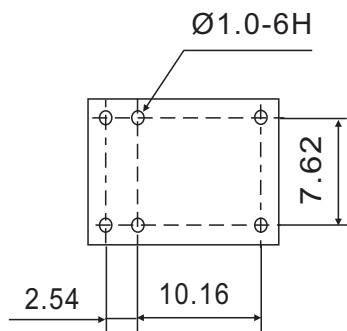

## GENERAL DATA

Insulation Resistance	100 MΩ Min. (DC 500V)
Dielectric Strength	1000 VAC, 50/60Hz between contact.
	1000 VAC, 50/60Hz between all elements.
Contact Material	Ag Alloy.
Contact Resistance	100 milliohms max. ( initial value )
Shock Resistance	Malfunction: 10G(11ms) ; Destructive: 100G(6ms)
Vibration Resistance	Malfunction: 10 to 55 Hz. at Double Amplitude of 1.5 mm
	Destructive: 10 to 55 Hz. at Double Amplitude of 1.5 mm
Operation Time	5 ms max.
Release Time	5 ms max.
Temperature Range	- 30°C ~ + 70°C
Expected Life	With operation rate 30/min.
	Mechanical - 10,000,000 operations min.
	Electrical - 50,000 operations min. at rated load.
Weight	4 grams

## FEATURES

- 1 Form A ( 1PST ) contact arrangement
- Small size (18.2x10.2x14.5mm) up to 5A/ 3A switching
- capacity for high density PC Board mounting technique
- Plastic insulation material designed for high temperature and better chemical solution performance
- Using at Domestic appliances, office machines, audio equipment, Automotive, etc.
- UL FILE NO.:E131959

## ORDERING INFORMATION

**LJ**   **A**   —   **12**   **S**  
 1      2                      3      4

- |                        |                         |
|------------------------|-------------------------|
| 1. Type                | 3. Coil Nominal Voltage |
| 2. Contact Arrangement | 4. Coil Sensitivity     |
| Nil : 1 Form C         | Nil :0.45W              |
| A : 1 Form A           | S :0.2 W                |
| B : 1 Form B           |                         |

## COIL DATA(0.2W,0.45W, at 25°C)

Coil Nominal Voltage (VDC)	Resistance Tol.±10% (Ohms)		Nominal Current (mA)		Maximum Pick Up Voltage (V)		Minimum Drop Out Voltage (V)
	0.45W	0.2W	0.45W	0.2W	0.45W	0.2W	
3	20	45	150.0	67.0	2.25	2.4	0.3
5	55	125	91.0	40.0	3.75	4.0	0.5
6	80	180	75.0	33.3	4.5	4.8	0.6
9	180	400	50.0	22.5	6.75	7.2	0.9
12	320	720	37.5	16.7	9.0	9.6	1.2
24	1,280	2,800	18.8	8.6	18.0	19.2	2.4
48	5,100		9.4		36.0		4.8

## CONTACT RATING

1 FORM A(1PST)	Resistive (Cos.θ = 1)	AC 125V	5A
		AC 250V /DC 30V	3A
1 FORM C(1PDT)	Resistive (Cos.θ = 1)	AC 250V / DC30V	3A

## DIMENSIONS(±0.2mm)

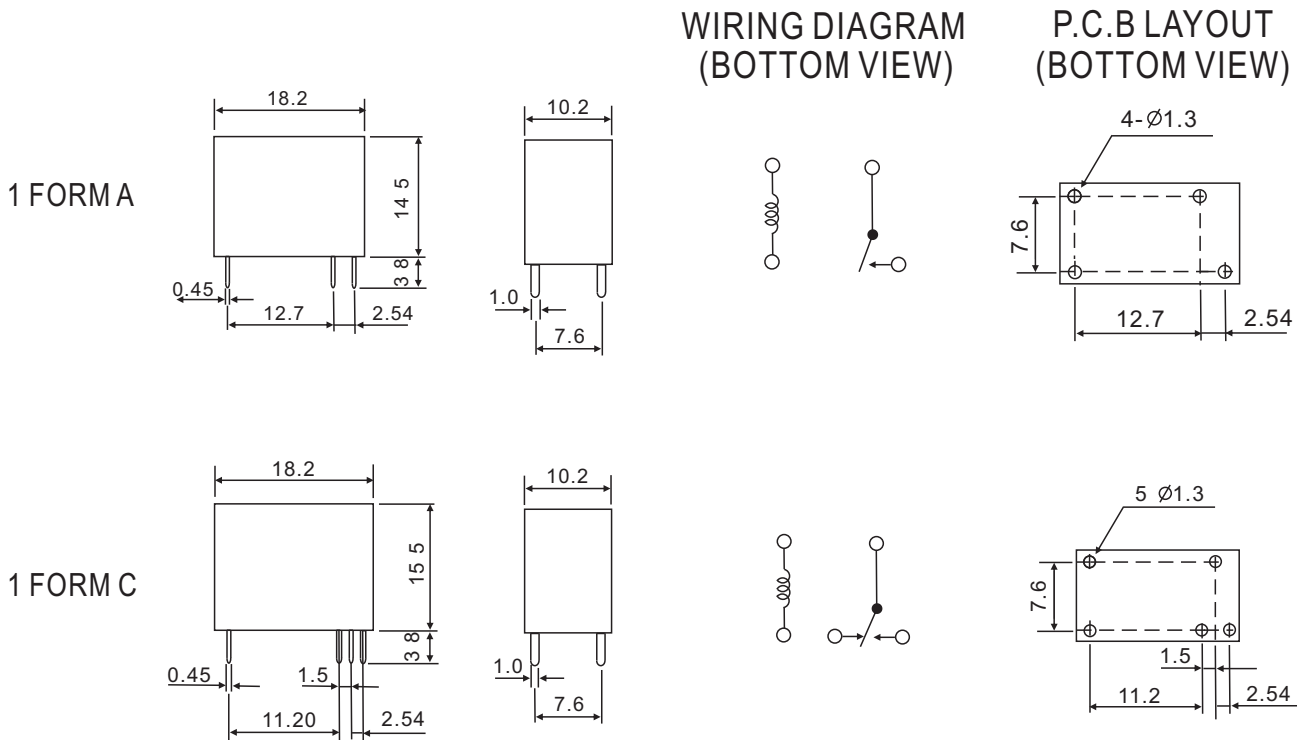

## GENERAL DATA

Insulation Resistance	100 MΩ Min. (DC 500V)
Dielectric Strength	750 VAC, 50/60Hz between contact.
	3,000(4,000) VAC, 50/60Hz between all elements.
Contact Material	Ag Alloy.
Contact Resistance	100 milliohms max. ( initial value )
Shock Resistance	Malfunction: 10G(11ms) ; Destructive: 100G(6ms)
Vibration Resistance	Malfunction: 10 to 55 Hz. at Double Amplitude of 1.5 mm
	Destructive: 10 to 55 Hz. at Double Amplitude of 1.5 mm
Operation Time	10 ms max.
Release Time	4 ms max.
Temperature Range	- 30°C ~ + 80°C
Expected Life	With operation rate 30/min.
	Mechanical - 10,000,000 operations min. Electrical - 100,000 operations min. at rated load.
Weight	9 grams



## FEATURES

- 2 Form C ( 2PDT) gold overlay silver-palladium cross-bar contacts
- High Sensitive type
- For high density PC Board mounting
- Using at telecommunication, domestic appliances, office machine, audio equipment, remote control.

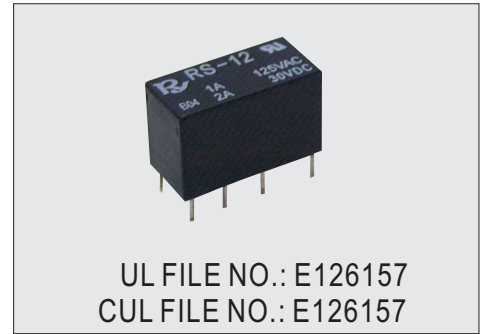

## ORDERING INFORMATION

RS — 12 — L

1                      2                      3

1. Type

2. Coil Nominal Voltage

3. Nil: 0.15W, (0.36W for 48VDC)

L : 0.2W, (0.45W for 48VDC)

## CONTACT RATING

2 Form C (2PDT)	AC 125V / 1.0 A	DC 24V / 2A
	Max. Switch Current	2A

## COIL DATA( at 25°C)

Coil Nominal Voltage (VDC)	Resistance Tol±10% (Ohms)		Nominal Current (mA)		Maximum Pick Up Voltage (V)	Minimum Drop Out Voltage (V)
	0.15W	0.2W	0.15W	0.2W		
3	60	45	50.0	66.7	2.4	0.150
5	167	125	29.9	40.0	4.0	0.250
6	240	180	25.0	33.3	4.8	0.300
9	540	405	16.7	22.2	7.2	0.450
12	960	720	12.5	16.7	9.6	0.600
24	3,840	2,880	6.3	8.3	19.2	1.200
	0.36W	0.45W	0.36W	0.45W		
48	6,400	5,120	7.5	9.4	36.0	2,400

## DIMENSIONS(±0.2mm)

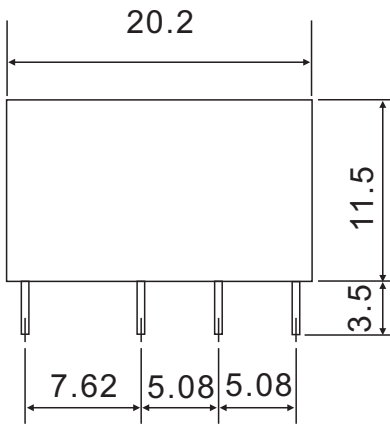

P.C.B LAYOUT  
(BOTTOM VIEW)

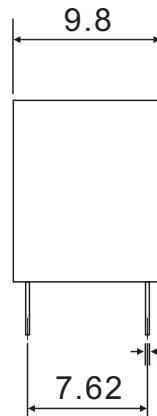

WIRING DIAGRAM  
(BOTTOM VIEW)

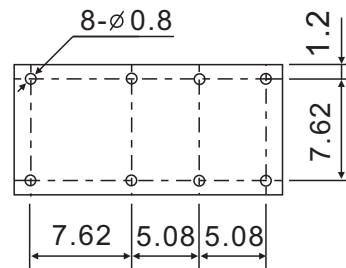
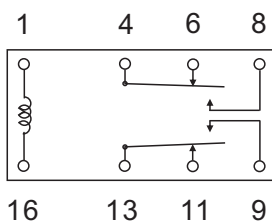

## GENERAL DATA

Insulation Resistance	1,000 MΩ Min. (DC 500V)
Dielectric Strength	500 VAC, 50/60Hz between contact.
	1,000 VAC, 50/60Hz between all elements.
Contact Material	Ag Alloy.
Contact Resistance	100 milliohms max. ( initial value )
Shock Resistance	Malfunction: 10G(11ms) ; Destructive: 100G(6ms)
Vibration Resistance	Malfunction: 10 to 55 Hz. at Double Amplitude of 1.5 mm
	Destructive: 10 to 55 Hz. at Double Amplitude of 1.5 mm
Operation Time	6 ms max.
Release Time	3 ms max.
Temperature Range	- 30°C ~ + 70°C
Expected Life	With operation rate 30/min.
	Mechanical - 20,000,000 operations min.
	Electrical - 200,000 operations min. at rated load.
Weight	5 grams

## FEATURES

- Small size (12.5x7.5x9.7mm) and light weight
- High Sensitive
- Washable type
- UL and CUL approved
- Using at Telecommunication, domestic appliances, etc

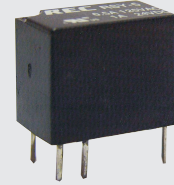

UL FILE NO.: E126157  
CUL FILE NO.: E126157

## ORDERING INFORMATION

RSY — 12 — L

1                      2                      3

1. Type
2. Coil Nominal Voltage
3. Nil: 0.15W  
L: 0.2 W

## CONTACT RATING

1 FORM C (1PDT)	Resistive (Cos.θ = 1)	AC 125V / 0.5A	DC 24V / 1A
		Max. Switch Current	1A

## COIL DATA(0.15W,0.2W, at 25°C)

Coil Nominal Voltage (VDC)	Resistance Tol.±10% (Ohms)		Nominal Current (mA)		Maximum Pick Up Voltage (V)	Minimum Drop Out Voltage (V)
	0.15W	0.2W	0.15W	0.2W		
3	60	45	50.0	66.7	2.4	0.3
5	167	125	30.0	40.0	4.0	0.5
6	240	180	25.0	33.3	4.8	0.6
9	540	405	16.6	22.2	7.2	0.9
12	960	720	12.5	16.7	9.6	1.2
24	3,840	2,880	6.25	8.3	19.2	2.4

## DIMENSIONS(±0.2mm)

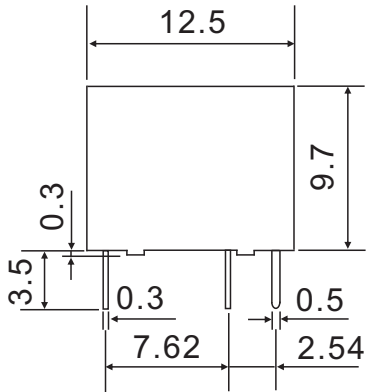

P.C.B LAYOUT  
(BOTTOM VIEW)

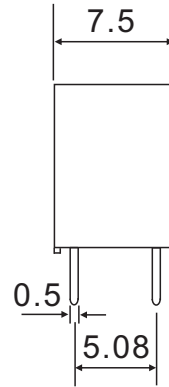

WIRING DIAGRAM  
(BOTTOM VIEW)

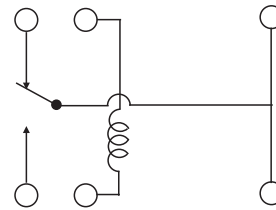
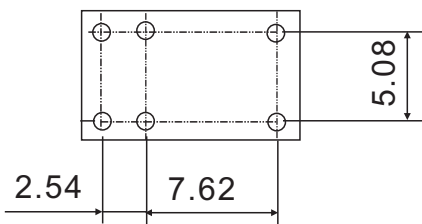

## GENERAL DATA

Insulation Resistance	1,000 MΩ Min. (DC 500V)
Dielectric Strength	400 VAC, 50/60Hz between contact.
	1,000 VAC, 50/60Hz between all elements.
Contact Material	Ag Alloy.
Contact Resistance	100 milliohms max. ( initial value )
Shock Resistance	Malfunction: 10G(11ms) ; Destructive: 100G(6ms)
Vibration Resistance	Malfunction: 10 to 55 Hz. at Double Amplitude of 1.5 mm
	Destructive: 10 to 55 Hz. at Double Amplitude of 1.5 mm
Operation Time	4 ms max.
Release Time	3 ms max.
Temperature Range	- 25°C ~ + 55°C
Expected Life	With operation rate 30/min.
	Mechanical - 1,000,000 operations min. Electrical - 100,000 operations min. at rated load.
Weight	2.2 grams

## FEATURES

- 10A cube relay
- 1 Form C ( 1PDT) contact arrangement
- Plastic material applied in high temperature and better chemical solution.
- Sealed type for washing procedure
- Using at home appliances, office machines, audio equipment, coffee pot , control units, etc.

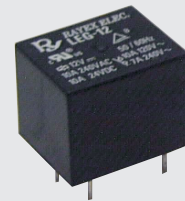

UL FILE NO. : E126157  
CUL FILE NO. : E126157  
TUV FILE NO. : R9754097

## ORDERING INFORMATION

**LEG 1A** \_\_\_\_\_ **12 H**

1            2                            3            4

1. Type
2. Contact Arrangement  
Nil : 1 Form C(1PDT)  
1A : 1 Form A(1PST-NO)
3. Coil Nominal Voltage
- 4 Nil:10A  
H: 5A

## COIL DATA(0.36W, at 25°C)

Coil Nominal Voltage (VDC)	Resistance Tol.±10% (Ohms )	Nominal Current (mA)	Maximum Pick Up Voltage (V)	Minimum Drop Out Voltage (V)
3	25	120	2.1	0.3
5	70	72	3.5	0.5
6	100	60	4.2	0.6
9	225	40	6.3	0.9
12	400	30	8.4	1.2
24	1,600	15	16.8	2.4
48	6,400	7.5	33.6	4.8

## CONTACT RATING

UL	Resistive (Cos.θ = 1)	AC 240V / DC 24V	10A
	Inductive (Cos.θ = 0.4)	AC 240V	5A
TUV	Resistive (Cos.θ = 1)	AC 120V	10A
		AC 240V / DC 24V	7A
	Inductive (Cos.θ = 0.4)	AC 240V	3A

## DIMENSIONS(±0.2mm)

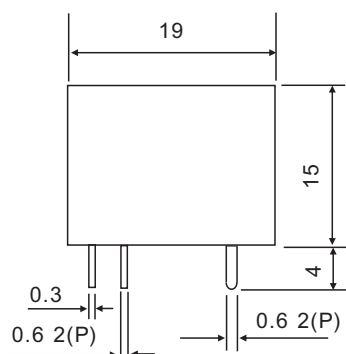

WIRING DIAGRAM  
(BOTTOM VIEW)

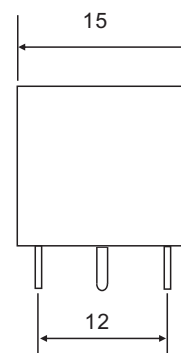
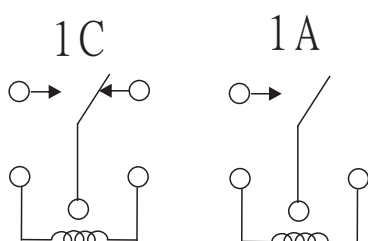

P.C.B LAYOUT  
(BOTTOM VIEW)

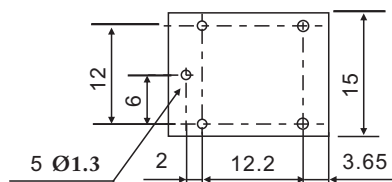

## GENERAL DATA

Insulation Resistance	100 MΩ Min. (DC 500V)
Dielectric Strength	750 VAC, 50/60Hz between contact.
	1,500 VAC, 50/60Hz between all elements.
Contact Material	Ag alloy.
Contact Resistance	100 milliohms max. ( initial value )
Shock Resistance	Malfunction: 10G(11ms) ; Destructive: 100G(6ms)
Vibration Resistance	Malfunction: 10 to 55 Hz. at Double Amplitude of 1.5 mm
	Destructive: 10 to 55 Hz. at Double Amplitude of 1.5 mm
Operation Time	8 ms max.
Release Time	5 ms max.
Temperature Range	- 25°C ~ + 80°C
Expected Life	With operation rate 30/min.
	Mechanical - 10,000,000 operations min.
	Electrical - 100,000 operations min. at rated load.
Weight	9 grams

## FEATURES

- Better construction for heat radiating
- 1A (1PST) and 1C (1PDT) contact form are available
- UL, CUL, TUV approved
- Using at home appliances, office machines, audio equipment, coffee pot, control units, etc

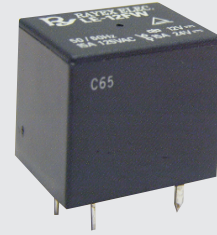

UL FILE NO. : E131959  
CUL FILE NO. : E131959  
TUV FILE NO. : R9452200

## ORDERING INFORMATION

LE   1A   —   12   T   W  
1        2                    3        4        5

- |                         |                   |
|-------------------------|-------------------|
| 1. Type                 | 4. Contact Rating |
| 2. Contact Arrangement  | T : 10A           |
| Nil : 1 Form C(1PDT)    | F : 15A           |
| 1A : 1 Form A(1PST-NO)  | 5. Enclosure      |
| 1B : 1 Form B(1PST-NC)  | W : Sealed Type   |
| 3. Coil Nominal Voltage |                   |

## COIL DATA(0.36W,0.63W, at 25°C )

Coil Nominal Voltage (VDC)	Resistance Tol.±10% (Ohms)		Nominal Current (mA)		Maximum Pick Up Voltage (V)	Minimum Drop Out Voltage (V)
	T	F	T	F		
3	25		120		2.25	0.3
5	70		72		3.75	0.5
6	100	57	60	105	4.50	0.6
9	225	128	40	70	6.75	0.9
12	400	225	30	53	9.00	1.2
24	1,600	1,600	15	15	18.00	2.4
48	6,400		7.5		36.00	4.8

## CONTACT RATING

T TYPE	Resistive (Cos.θ = 1)	AC 120V / DC 24V	10A
		AC 240V	6A
	Inductive (Cos.θ = 0.4)	AC 120V / DC 24V	6A
		AC 240V	3A
F TYPE	Resistive (Cos.θ = 1)	DC 24V	15A
		Making Capacity	30A

## DIMENSIONS(±0.2mm)

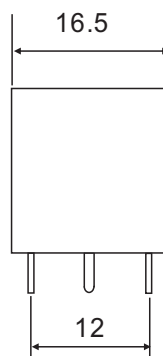
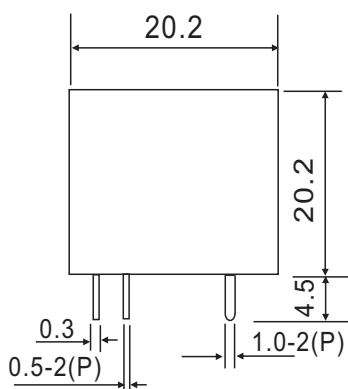

WIRING DIAGRAM  
(BOTTOM VIEW)

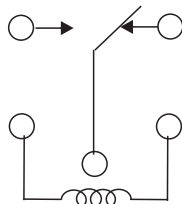

P.C.B LAYOUT  
(BOTTOM VIEW)

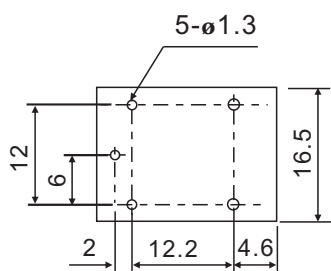

## GENERAL DATA

Insulation Resistance	100 MΩ Min. (DC 500V)
Dielectric Strength	750 VAC, 50/60Hz between contact.
	1,500 VAC, 50/60Hz between all elements.
Contact Material	Ag Alloy
Contact Resistance	100 milliohms max. ( initial value )
Shock Resistance	Malfunction: 10G(11ms) ; Destructive: 100G(6ms)
Vibration Resistance	Malfunction: 10 to 55 Hz. at Double Amplitude of 1.5 mm
	Destructive: 10 to 55 Hz. at Double Amplitude of 1.5 mm
Operation Time	10 ms max.
Release Time	5 ms max.
Temperature Range	- 40°C ~ + 85°C
Expected Life	With operation rate 30/min.
	Mechanical - 10,000,000 operations min.
	Electrical - 100,000 operations min. at rated load.
Weight	12 grams



## FEATURES

- Employment of suitable plastic materials to be applied to high temperature and various chemical solution
- UL, CUL, TUV approved
- Power consumption: 0.33W~0.45W
- Using at cooking appliances, air conditioners, audio equipments, domestic appliances, car control units, etc.

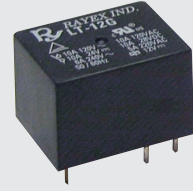

UL FILE NO. : E126157  
 CUL FILE NO. : E126157  
 TUV FILE NO. : R9452432

## ORDERING INFORMATION

LT    —    12    G    S  
 1                      2                      3                      4

1. Type
2. Coil Nominal Voltage
3. Contact Rating  
G : 10A
4. Coil Sensitivity  
Nil : 0.45W  
S : 0.33W

## COIL DATA(0.45W,0.33W, at 25°C)

Coil Nominal Voltage (VDC)	Resistance Tol.±10% (Ohms)		Nominal Current (mA)		Maximum Pick Up Voltage (V)	Minimum Drop Out Voltage (V)
	0.45W	0.33W	0.45W	0.33W		
3	20	27	150.0	111.1	2.1	0.3
5	56	75	89.2	62.5	3.5	0.5
6	80	110	75.0	54.5	4.2	0.6
9	180	250	50.0	36.0	6.3	0.9
12	320	440	37.5	30.0	8.4	1.2
24	1,280	1,750	18.7	13.4	16.8	2.4
48	4,600		10.4		33.6	4.8

## CONTACT RATING

Resistive (Cos.θ = 1)	AC 120V / DC 24V	10A
	AC 240V	6A
Inductive (Cos.θ = 0.4)	AC 120V / DC 24V	6A
	AC 240V	3A

## DIMENSIONS(±0.2mm)

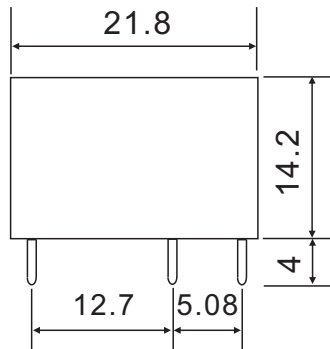

WIRING DIAGRAM  
(BOTTOM VIEW)

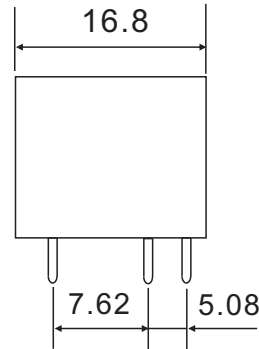
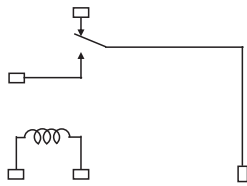

P.C.B LAYOUT  
(BOTTOM VIEW)

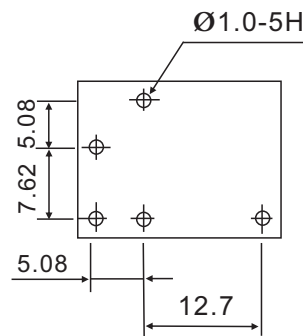

## GENERAL DATA

Insulation Resistance	100 MΩ Min. (DC 500V)
Dielectric Strength	750 VAC, 50/60Hz between contact.
	1,500 VAC, 50/60Hz between all elements.
Contact Material	Ag Alloy.
Contact Resistance	100 milliohms max. ( initial value )
Shock Resistance	Malfunction: 10G(11ms) ; Destructive: 100G(6ms)
Vibration Resistance	Malfunction: 10 to 55 Hz. at Double Amplitude of 1.5 mm
	Destructive: 10 to 55 Hz. at Double Amplitude of 1.5 mm
Operation Time	10 ms max.
Release Time	10 ms max.
Temperature Range	- 25°C ~ + 60°C
Expected Life	With operation rate 30/min.
	Mechanical - 10,000,000 operations min.
	Electrical - 100,000 operations min. at rated load.
Weight	10 grams



# LMR SERIES

RAYEX ELEC.

ROHS

## FEATURES

- High sensitive type
- Dielectric strength AC 5,000V
- 8mm insulation distance
- Using at home appliances, microwave ovens, air conditioners, audio equipment, temperature controller

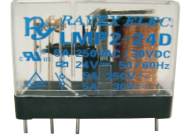
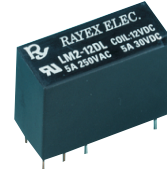

- UL FILE NO. : E126157,
- CUL FILE NO. : E126157
- TUV FILE NO. :R50054883

## ORDERING INFORMATION

LMR 1 H A — xx D L  
 1 2 3 4 5 6 7

- |             |              |
|-------------|--------------|
| 1. Type     | 4.Nil:1C     |
| 2. 1:1 Post | A:N/C        |
| 2: 2 Post   | B:N/C        |
| 3.Nil:5 Pin | 5.Coil Voil  |
| H:8 Pin     | 6.D:DC       |
|             | 7.L:H:20.5mm |

## COIL DATA (at 25°C)

DC 0.53 W				
Coil Nominal Voltage(VDC)	Resistance Tol.±10% (Ohms)	Nominal Current (mA)	Maximum Pick Up Voltage (V)	Minimum Drop Out Voltage (V)
5	47	106.4	4	0.5
12	270	44.4	9.6	1.2
24	1,100	21.8	19.2	2.4

## CONTACT RATING

LMR1	TYPE (1PDT)	Resistive (Cos.θ = 1)	AC 250V / DC 30V	12A
LMR2	TYPE (2PDT)	Resistive (Cos.θ = 1)	AC 250V / DC 30V	8A
LMR1H	TYPE (1PDT)	Resistive (Cos.θ = 1)	AC 250V / DC 30V	16A

## DIMENSIONS(±0.2mm)

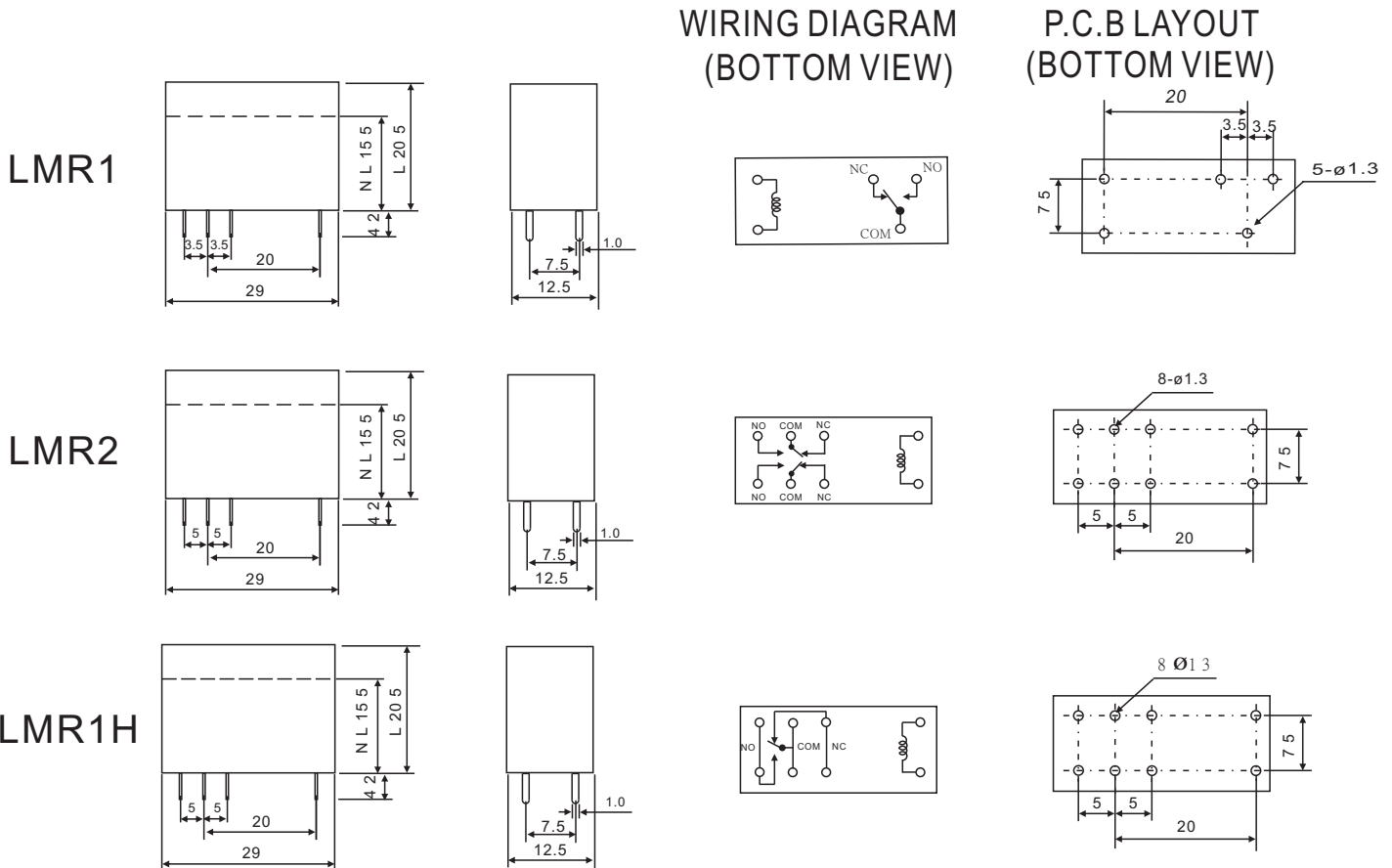

## GENERAL DATA

Insulation Resistance	1,000 MΩ Min. (DC 500V)
Dielectric Strength	1,000 VAC, 50/60Hz between contact.
	5,000 VAC, 50/60Hz between all elements.
Contact Material	Ag .Alloy.
Contact Resistance	100 milliohms max. ( initial value )
Shock Resistance	Malfunction: 10G(11ms) ; Destructive: 100G(6ms)
Vibration Resistance	Malfunction: 10 to 55 Hz. at Double Amplitude of 1.5 mm
	Destructive: 10 to 55 Hz. at Double Amplitude of 1.5 mm
Operation Time	15 ms max.
Release Time	10 ms max.
Temperature Range	- 40°C ~ + 85°C
Expected Life	With operation rate 30/min.
	Mechanical - 10,000,000 operations min.
	Electrical - 100,000 operations min. at rated load.
Weight	12 garms



## CONTACT RATING

LM1	TYPE (1PDT)	Resistive (Cos.θ = 1)	AC 250V / DC 30V	12A
LM2	TYPE (2PDT)	Resistive (Cos.θ = 1)	AC 250V / DC 30V	8A
LM1H	TYPE (1PDT)	Resistive (Cos.θ = 1)	AC 250V / DC 30V	16A

## DIMENSIONS(±0.2mm)

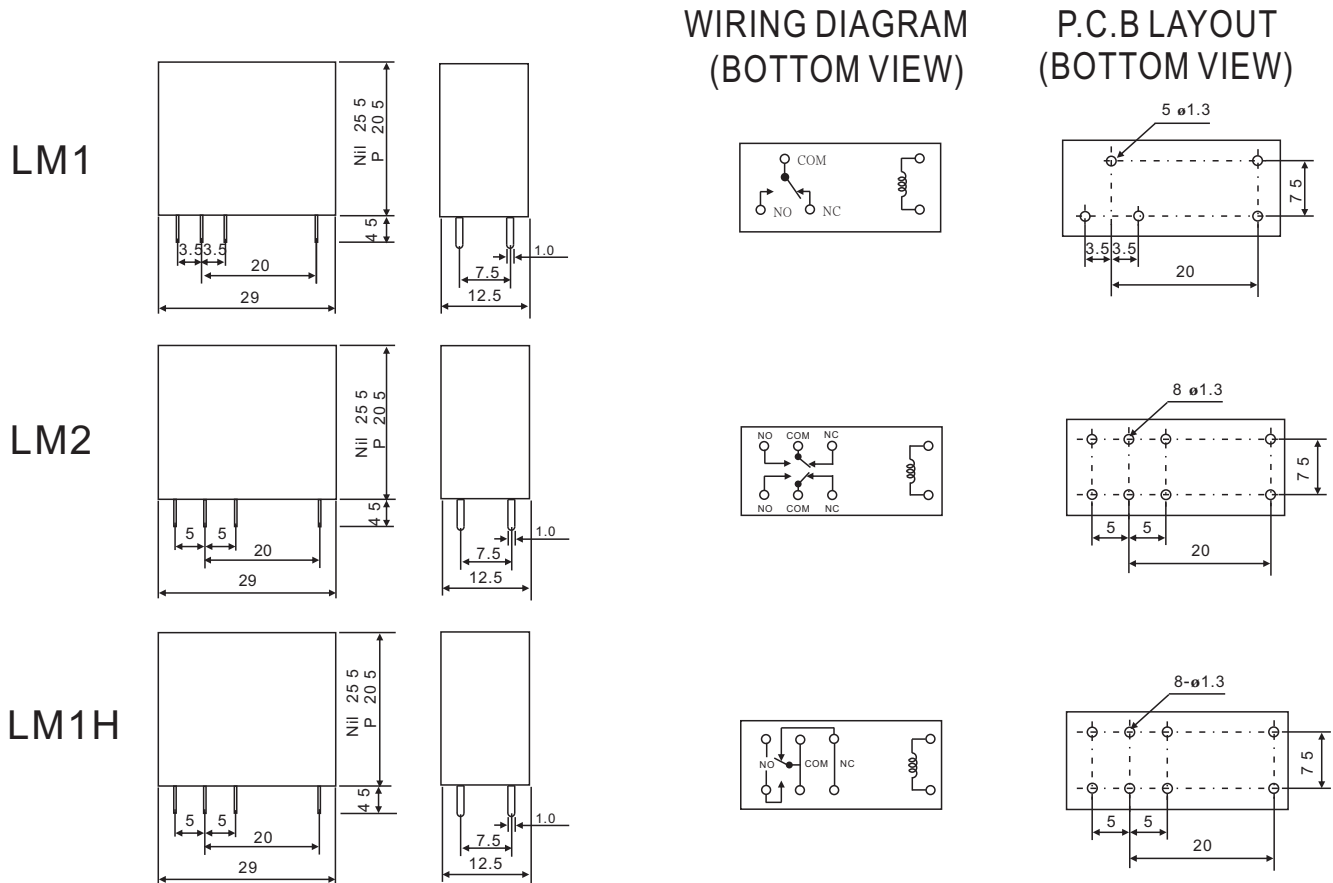

## GENERAL DATA

Insulation Resistance	1,000 MΩ Min. (DC 500V)
Dielectric Strength	1,000 VAC, 50/60Hz between contact.
	5,000 VAC, 50/60Hz between all elements.
Contact Material	Ag Alloy.
Contact Resistance	100 milliohms max. ( initial value )
Shock Resistance	Malfunction: 10G(11ms) ; Destructive: 100G(6ms)
Vibration Resistance	Malfunction: 10 to 55 Hz. at Double Amplitude of 1.5 mm
	Destructive: 10 to 55 Hz. at Double Amplitude of 1.5 mm
Operation Time	15 ms max.
Release Time	10 ms max.
Temperature Range	- 40°C ~ + 80°C
Expected Life	With operation rate 30/min.
	Mechanical - 10,000,000 operations min.
	Electrical - 100,000 operations min. at rated load.
Weight	Standard Type : 17 grams, , R Type : 12 garms

## FEATURES

- Up to 30A switching capacity in 1PST and 20A switching in 1PDT arrangement
- Open-frame and plastic sealed types are available
- Using at home appliances, power switching appliances, car controller, heating, ventilating, and conditioning systems



UL FILE NO.: E126157  
 CUL FILE NO.: E126157  
 TUV FILE NO.: R50008132

## ORDERING INFORMATION

L90   A   S   —   12   A   W   L  
 1        2        3                    4        5        6        7

- |   |                              |
|---|------------------------------|
| 1. Type   | 4. Coil Nominal Voltage      |
| 2. Contact Arrangement                                | 5. Coil Nominal Voltage Type |
| Nil : 1 Form C(1PDT)                                  | Nil : DC                     |
| A : 1 Form A(1PST-NO)                                 | A : AC                       |
| B : 1 Form B(1PST-NC)                                 | 6. Enclosure Type            |
| 3. Common Terminals Type                              | Nil : Open Type              |
| Nil : Standard Type                                   | W : Sealed Type              |
| S : Without Common Terminal<br>between coil terminals | 7. L:40A                     |

## COIL DATA(at 25°C )

DC 0.9 W				AC 1.2 VA			
Coil Nominal Voltage (VDC)	Resistance Tol.±10% (Ohms)	Maximum Pick Up Voltage (V)	Minimum Drop Out Voltage (V)	Coil Nominal Voltage (50/60Hz)	Resistance Tol.±10% (Ohms)	Maximum Pick Up Voltage (V)	Minimum Drop Out Voltage (V)
5	27	3.75	0.5	6	10	5.1	0.6
6	40	4.5	0.6	12	43	10.2	1.2
9	97	6.75	0.9	24	160	20.4	2.4
12	155	9.0	1.2	110	3,160	93.5	11.0
18	380	13.5	1.8	220	13,490	187.0	22.0
24	660	18.0	2.4				
48	2,560	36.0	4.8				

## CONTACT RATING

1A(1PST-NO)	Resistive (Cos.θ = 1)	AC 240V / 30A	AC 277V / 20A	DC 30V / 20A
1B(1PST-NC)	Resistive (Cos.θ = 1)	AC 240V / 20A	AC 277V / 15A	DC 30V / 10A
1C(1PDT)	Resistive (Cos.θ = 1)	NO : AC 240V / 30A	NO : AC 277V / 20A	NO:DC 30V / 20A
	Resistive (Cos.θ = 1)	NC : AC 240V / 20A	NC : AC 277V / 15A	NC:DC 30V / 10A
L:1C(1PDT)	Resistive (Cos.θ = 1)	AC 240V / DC 30V		40A

## DIMENSIONS(±0.2mm)

SEALED TYPE

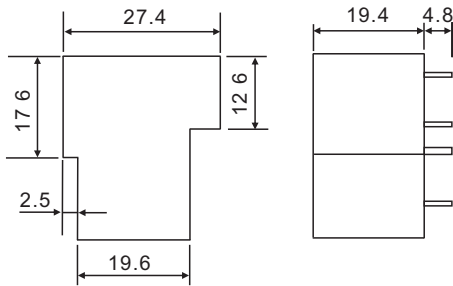

OPEN TYPE

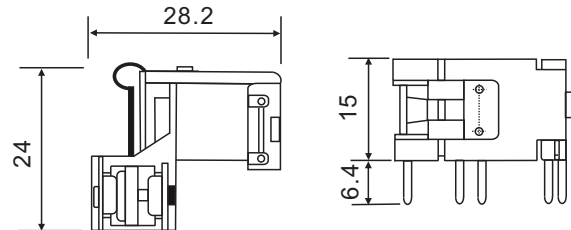

P.C.B LAYOUT  
(BOTTOM VIEW)

WIRING DIAGRAM(BOTTOM VIEW)

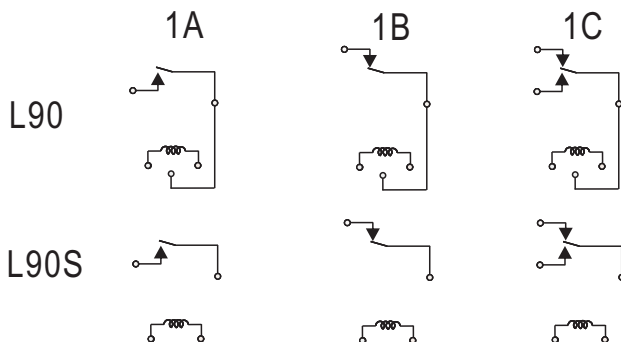

L90

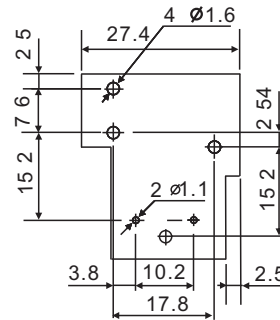

L90S

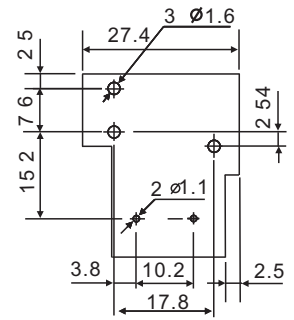

## GENERAL DATA

Insulation Resistance	500 MΩ Min. (DC 500V)
Dielectric Strength	1,500 VAC, 50/60Hz between contact.
	2,000 VAC(L90S:2500), 50/60Hz between all elements
Contact Material	Ag Alloy.
Contact Resistance	50 milliohms max. ( initial value )
Shock Resistance	Malfunction: 10G(11ms) ; Destructive: 100G(6ms)
Vibration Resistance	Malfunction: 10 to 55 Hz. at Double Amplitude of 1.5 mm
	Destructive: 10 to 55 Hz. at Double Amplitude of 1.5 mm
Operation Time	15 ms max.
Release Time	15 ms max.
Contact gap	1.0mm
Temperature Range	- 55°C ~ + 85°C
Expected Life	With operation rate 30/min.
	Mechanical - 10,000,000 operations min. Electrical - 100,000 operations min. at rated load.
Weight	25 grams





## CONTACT RATING

1A(1PST-NO)	Resistive (Cos.θ = 1)	AC 240V / 30A	AC 277V / 20A	DC 30V / 20A
1B(1PST-NC)	Resistive (Cos.θ = 1)	AC 240V / 20A	AC 277V / 15A	DC 30V / 10A
1C(1PDT)	Resistive (Cos.θ = 1)	NO : AC 240V / 30A	NO : AC 277V / 20A	NO:DC 30V / 20A
	Resistive (Cos.θ = 1)	NC : AC 240V / 20A	NC : AC 277V / 15A	NC:DC 30V / 10A
L:1C(1PDT)	Resistive (Cos.θ = 1)	AC 240V/DC 30V		40A

## DIMENSIONS(±0.2mm)

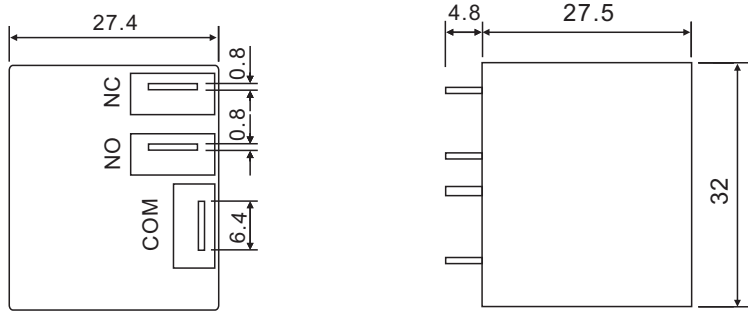

P.C.B LAYOUT  
(BOTTOM VIEW)

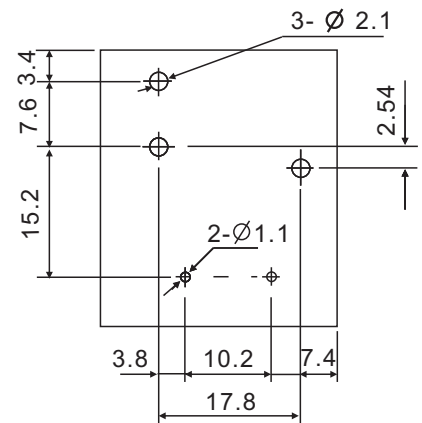

WIRING DIAGRAM(BOTTOM VIEW)

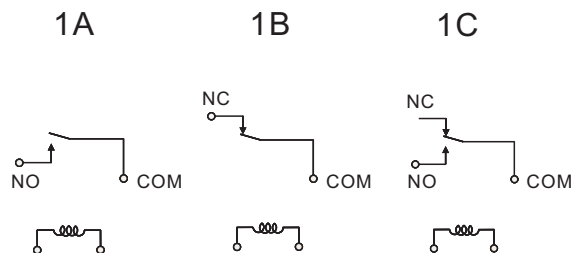

## GENERAL DATA

Insulation Resistance	500 MΩ Min. (DC 500V)
Dielectric Strength	1,500 VAC, 50/60Hz between contact.
	2,000 VAC, 50/60Hz between all elements.
Contact Material	Ag Alloy.
Contact Resistance	50 milliohms max. ( initial value )
Shock Resistance	Malfunction: 10G(11ms) ; Destructive: 100G(6ms)
Vibration Resistance	Malfunction: 10 to 55 Hz. at Double Amplitude of 1.5 mm
	Destructive: 10 to 55 Hz. at Double Amplitude of 1.5 mm
Operation Time	15 ms max.
Release Time	15 ms max.
Temperature Range	- 55°C ~ + 85°C
Expected Life	With operation rate 30/min.
	Mechanical - 10,000,000 operations min.
	Electrical - 100,000 operations min. at rated load.
Weight	30 grams



## CONTACT RATING

1A(1PST-NO)	Resistive (Cos.θ = 1)	AC 240V / 30A	AC 277V / 20A	DC 30V / 20A
1B(1PST-NC)	Resistive (Cos.θ = 1)	AC 240V / 20A	AC 277V / 15A	DC 30V / 10A
1C(1PDT)	Resistive (Cos.θ = 1)	NO : AC 240V / 30A	NO : AC 277V / 20A	NO:DC 30V / 20A
	Resistive (Cos.θ = 1)	NC : AC 240V / 20A	NC : AC 277V / 15A	NC:DC 30V / 10A
L:1C(1PDT)	Resistive (Cos.θ = 1)	AC 240V/ DC 30V		40A

## DIMENSIONS(±0.2mm)

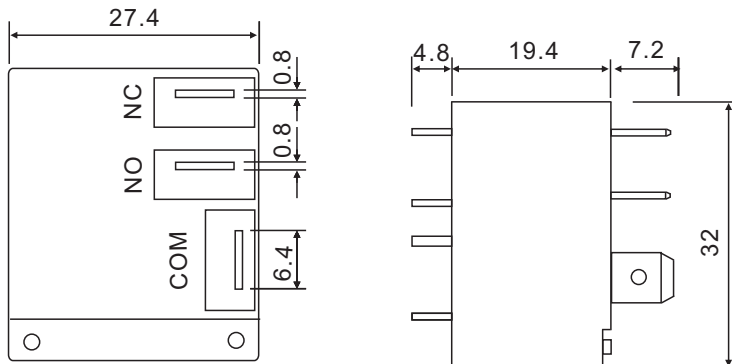

P.C.B LAYOUT  
(BOTTOM VIEW)

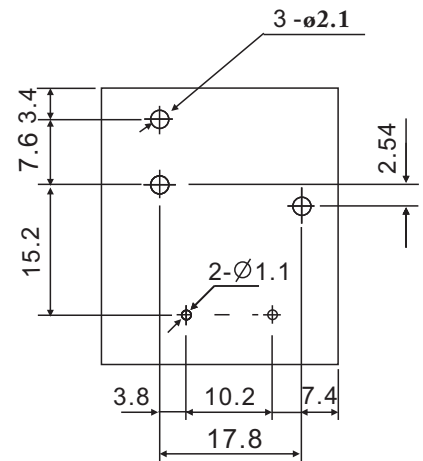

WIRING DIAGRAM(BOTTOM VIEW)

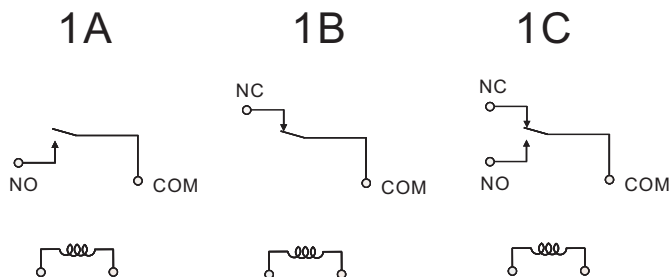

## GENERAL DATA

Insulation Resistance	500 MΩ Min. (DC 500V)
Dielectric Strength	1,500 VAC, 50/60Hz between contact.
	2,000 VAC, 50/60Hz between all elements.
Contact Material	Ag Alloy.
Contact Resistance	50 milliohms max. ( initial value )
Shock Resistance	Malfunction: 10G(11ms) ; Destructive: 100G(6ms)
Vibration Resistance	Malfunction: 10 to 55 Hz. at Double Amplitude of 1.5 mm
	Destructive: 10 to 55 Hz. at Double Amplitude of 1.5 mm
Operation Time	15 ms max.
Release Time	15 ms max.
Temperature Range	- 55°C ~ + 85°C
Expected Life	With operation rate 30/min.
	Mechanical - 10,000,000 operations min. Electrical - 100,000 operations min. at rated load.
Weight	28 grams



## CONTACT RATING

1A(1PST-NO)	Resistive (Cos.θ = 1)	AC 240V / 30A	AC 277V / 20A	DC 30V / 20A
1B(1PST-NC)	Resistive (Cos.θ = 1)	AC 240V / 20A	AC 277V / 15A	DC 30V / 10A
1C(1PDT)	Resistive (Cos.θ = 1)	NO : AC 240V / 30A	NO : AC 277V / 20A	NO:DC 30V / 20A
	Resistive (Cos.θ = 1)	NC : AC 240V / 20A	NC : AC 277V / 15A	NC:DC 30V / 10A
L:1C(1PDT)	Resistive (Cos.θ = 1)	AC 240V/ DC 30V		40A

## DIMENSIONS(±0.2mm)

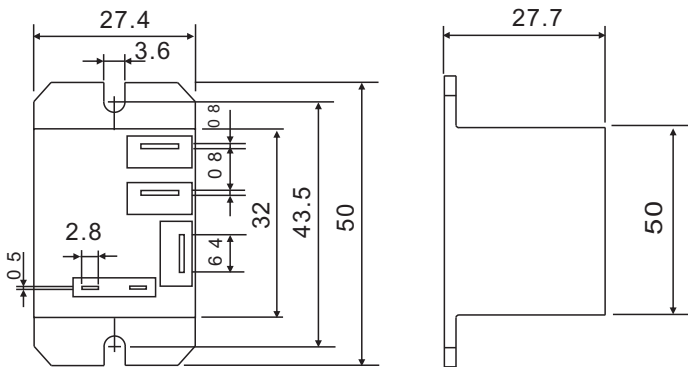

P.C.B LAYOUT  
(BOTTOM VIEW)

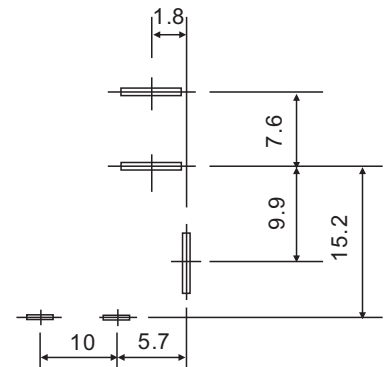

WIRING DIAGRAM(BOTTOM VIEW)

1A

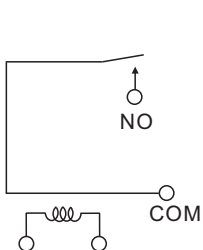

1B

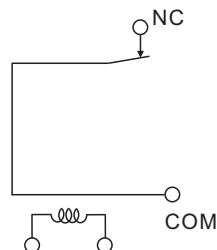

1C

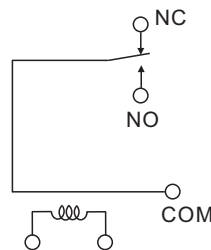

## GENERAL DATA

Insulation Resistance	500 MΩ Min. (DC 500V)
Dielectric Strength	1,500 VAC, 50/60Hz between contact.
	2,000 VAC, 50/60Hz between all elements.
Contact Material	Ag Alloy.
Contact Resistance	50 milliohms max. ( initial value )
Shock Resistance	Malfunction: 10G(11ms) ; Destructive: 100G(6ms)
Vibration Resistance	Malfunction: 10 to 55 Hz. at Double Amplitude of 1.5 mm
	Destructive: 10 to 55 Hz. at Double Amplitude of 1.5 mm
Operation Time	15 ms max.
Release Time	15 ms max.
Temperature Range	- 55°C ~ + 85°C
Expected Life	With operation rate 30/min.
	Mechanical - 10,000,000 operations min. Electrical - 100,000 operations min. at rated load.
Weight	34 grams

## FEATURES

- 5A,10A switching capabilities.
- Subminiature,standard PC layout.
- Sealed&Unsealed types available.



## ORDERING INFORMATION

**RMA** ——— **12** **S**

1                      2              3              4

1. Type
2. Nil: 1 Form C  
1A: 1 Form A
- 3.Coil Nominal Voltage.
- 4.Nil:0.45W  
S:0.2W

## CONTACT RATING

1 Form A(1PST)	Resistive (Cos.θ = 1)	AC 120V	10A
	Resistive (Cos.θ = 1)	AC 250 V / DC 30V	5A
1 Form C(1PDT)	Resistive (Cos.θ = 1)	AC 250 V / DC 30V	5A

## COIL DATA(0.45W,0.2W at 25°C)

Coil Nominal Voltage (VDC)	Resistance Tol.±10% (Ohms )		Nominal Current (mA)		Maximum Pick Up Voltage (V)	Minimum Drop Out Voltage (V)
	0.45W	0.2W	0.45W	0.2W		
5	55	125	91	40	3.75	0.25
12	320	720	37.5	16.7	9.0	0.6
24	1280	2800	18.8	8.6	18.0	1.2

## DIMENSIONS(±0.2mm)

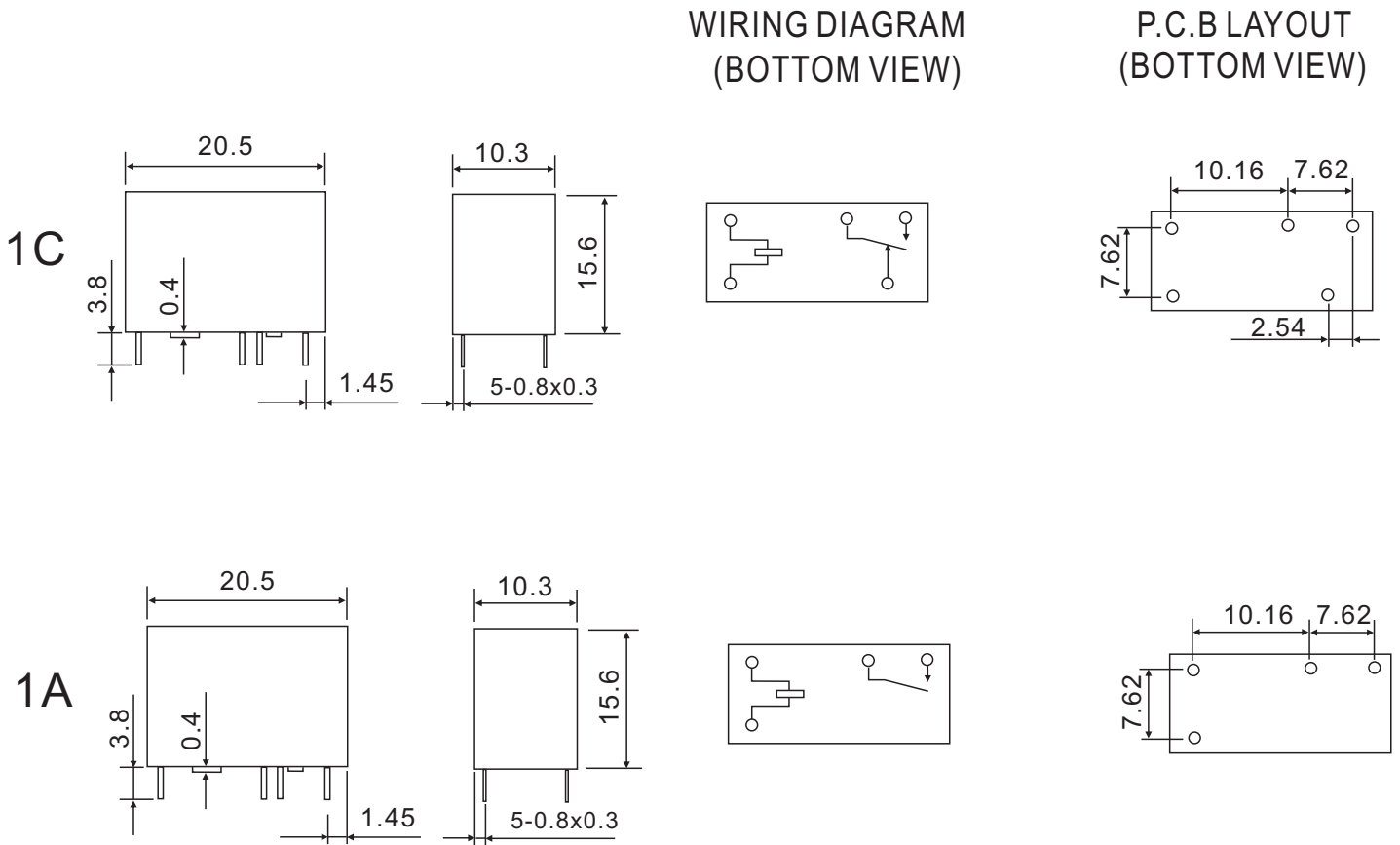

## GENERAL DATA

Insulation Resistance	100 MΩ Min. (DC 500V)
Dielectric Strength	1000 VAC, 50/60Hz between contact.
	4000 VAC, 50/60Hz between all elements.
Contact Material	Ag alloy
Contact Resistance	100 milliohms max. ( initial value )
Shock Resistance	Malfunction: 30g ; Destructive: 100G(6ms)
Vibration Resistance	Malfunction: 10 to 55 Hz. at Double Amplitude of 1.5 mm
	Destructive: 10 to 55 Hz. at Double Amplitude of 1.5 mm
Operation Time	10 ms max.
Release Time	5 ms max.
Temperature Range	- 40°C ~ + 70°C
Expected Life	With operation rate 30/min.
	Mechanical - 10,000,000 operations min.
	Electrical - 100,000 operations min. at rated load.
Weight	7 grams





## DIMENSIONS(±0.2mm)

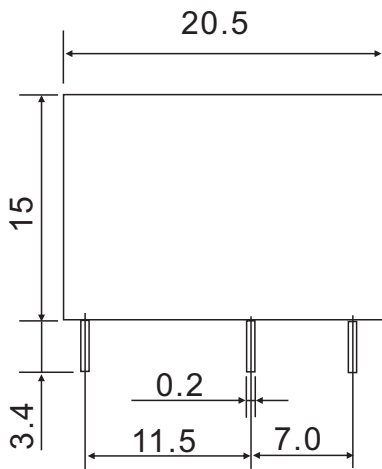

P.C.B LAYOUT  
(BOTTOM VIEW)

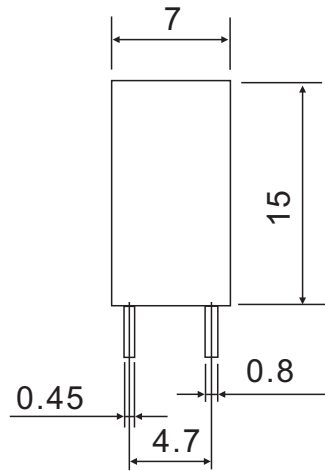

WIRING DIAGRAM  
(BOTTOM VIEW)

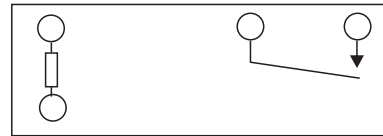
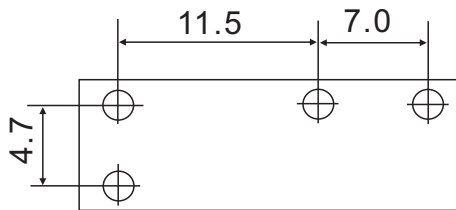

## GENERAL DATA

Insulation Resistance	1000 MΩ Min. (DC 500V)
Dielectric Strength	750 VAC, 50/60Hz between contact.
	4000 VAC, 50/60Hz between all elements.
Contact Material	Ag alloy
Contact Resistance	100 milliohms max. ( initial value )
Shock Resistance	Functional:100m/s <sup>2</sup> 11ms Survival:1000m/s <sup>2</sup> (6ms)
Vibration Resistance	Malfunction: 10 to 55 Hz. at Double Amplitude of 1.5 mm
	Destructive: 10 to 55 Hz. at Double Amplitude of 1.5 mm
Operation Time	10 ms max.
Release Time	5 ms max.
Temperature Range	- 40°C ~ + 85°C
Expected Life	With operation rate 30/min.
	Mechanical - 10,000,000 operations min.
	Electrical - 100,000 operations min. at rated load.
Weight	4 grams



## DIMENSIONS(±0.2mm)

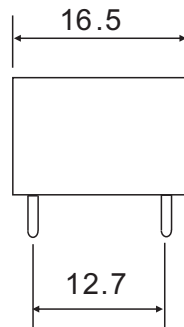
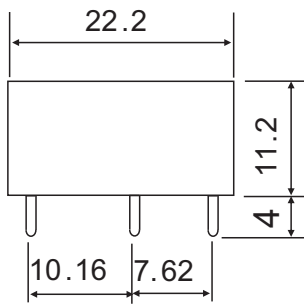

WIRING DIAGRAM  
(BOTTOM VIEW)

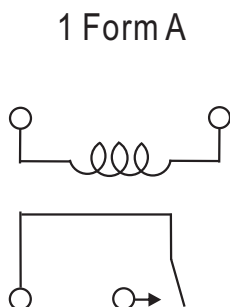
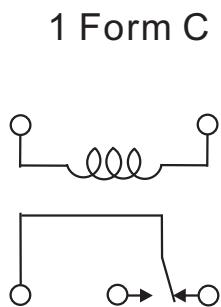

P.C.B LAYOUT  
(BOTTOM VIEW)

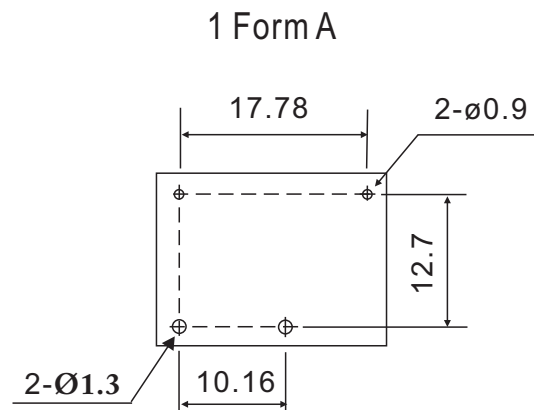
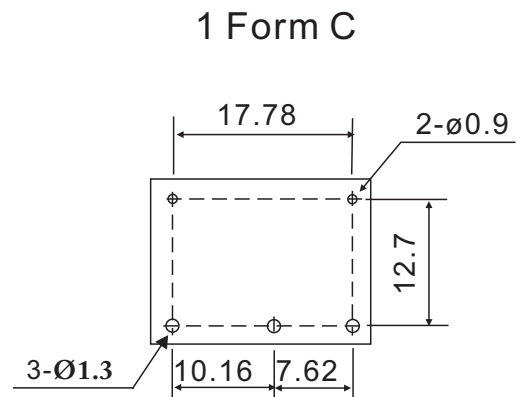

## GENERAL DATA

Insulation Resistance	100 MΩ Min. (DC 500V)
Dielectric Strength	750 VAC, 50/60Hz between contact.
	1,500 VAC, 50/60Hz between all elements.
Contact Material	Ag Alloy .
Contact Resistance	100 milliohms max. ( initial value )
Shock Resistance	Malfunction: 10G(11ms) ; Destructive: 100G(6ms)
Vibration Resistance	Malfunction: 10 to 55 Hz. at Double Amplitude of 1.5 mm
	Destructive: 10 to 55 Hz. at Double Amplitude of 1.5 mm
Operation Time	10 ms max.
Release Time	4 ms max.
Temperature Range	- 40°C ~ + 70°C
Expected Life	With operation rate 30/min.
	Mechanical - 10,000,000 operations min.
	Electrical - 100,000 operations min. at rated load.
Weight	9 grams

## FEATURES

- 20A continuous contact rating at 85°
- 1A (1PST) and 1C (1PDT) contact arrangement
- Small size (20.5x15x22mm) with high performance
- Using at air conditioner, electrical heater, remote-controlled TV, automatic control and household electric devices.



## ORDERING INFORMATION

AM1
A
12

1
2
3

1. Type
2. Contact Arrangement  
 Nil : 1 Form C  
 A : 1 Form A
3. Coil Nominal Voltage

## CONTACT RATING

1 FORM A (SPST)	Resistive (Cos.θ = 1)	DC 14V	20A
1 FORM C (SPDT)	Resistive (Cos.θ = 1)	NO:DC 14V / 20A	NC:DC 14V / 10A

## COIL DATA(1.5W, at 25°C)

Coil Nominal Voltage (VDC)	Resistance Tol. 10% (Ohms)	Nominal Current (mA)	Maximum Pick Up Voltage (V)	Minimum Drop Out Voltage (V)
12	96	122	8.4	1.2
24	384	61.7	16.8	2.4

## DIMENSIONS(±0.2mm)

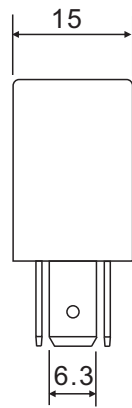
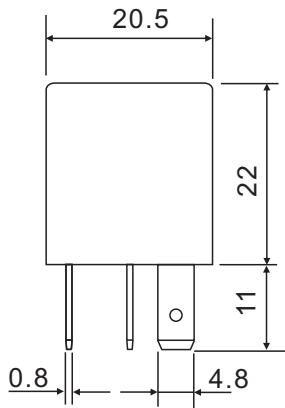

## WIRING DIAGRAM (BOTTOM VIEW)

1 Form C

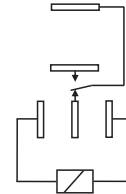

## P.C.B LAYOUT (BOTTOM VIEW)

1 Form C

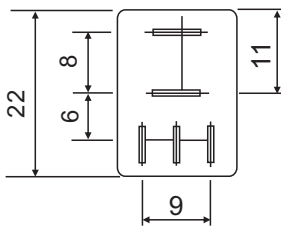

1 Form A

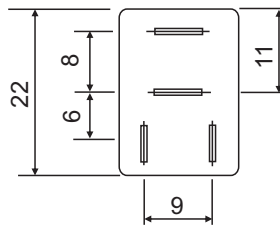

1 Form A

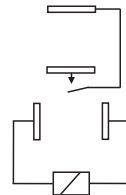

## GENERAL DATA

Insulation Resistance	50 MΩ Min. (DC 500V)
Dielectric Strength	500 VAC, 50/60Hz between contact.
	500 VAC, 50/60Hz between all elements.
Contact Material	Ag Alloy.
Contact Resistance	100 milliohms max. ( initial value )
Shock Resistance	Malfunction: 10G(11ms) ; Destructive: 100G(6ms)
Vibration Resistance	Malfunction: 10 to 55 Hz. at Double Amplitude of 1.5 mm
	Destructive: 10 to 55 Hz. at Double Amplitude of 1.5 mm
Operation Time	10 ms max.
Release Time	10 ms max.
Temperature Range	- 40°C ~ + 85°C
Expected Life	With operation rate 30/min.
	Mechanical - 10,000,000 operations min.
	Electrical - 100,000 operations min. at rated load.
Weight	20 grams

## FEATURES

- Contact rated load up to 30A/14VDC.
- Multiple choices for cover type.
- Coil enable parallel resistance reduce the operating power.
- Using at air condition control, halogen head lamp control, horn control, fog lamp control, etc.



## ORDERING INFORMATION

AM2 — 12 P  
1                      2                      3

1. Type  
2. Coil Nominal Voltage  
3. Cover Type  
B : Non-Bracket  
P : Plastic Bracket

## CONTACT RATING

1PST-NO	Resistive (Cos.θ = 1)	DC 14V	30A
---------	-----------------------	--------	-----

## COIL DATA(1.8W, at 25°C)

Coil Nominal Voltage (VDC)	Resistance Tol.±10% (Ohms)	Nominal Current (mA)	Maximum Pick Up Voltage (v)	Minimum Drop Out Voltage (V)
12	80	150	8.4	1.2
24	320	75	16.8	2.4

## DIMENSIONS(±0.2mm)

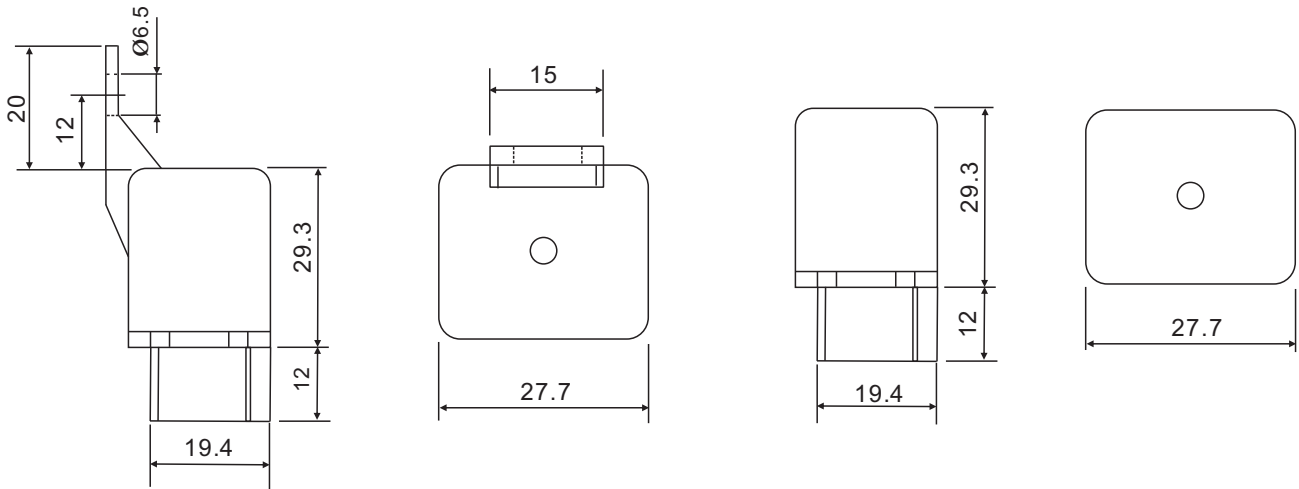

WIRING DIAGRAM  
(BOTTOM VIEW)

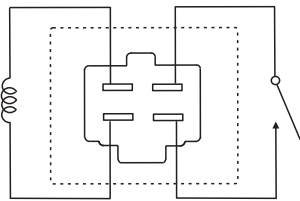

P.C.B LAYOUT  
(BOTTOM VIEW)

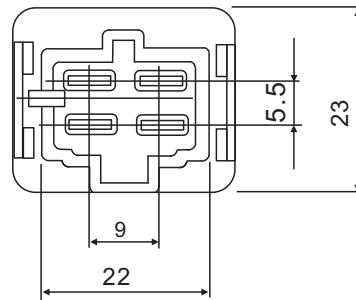

## GENERAL DATA

Insulation Resistance	100 M $\Omega$ Min. (DC 500V)
Dielectric Strength	500 VAC, 50/60Hz between contact.
	750 VAC, 50/60Hz between all elements.
Contact Material	Ag alloy.
Contact Resistance	50 milliohms max. ( initial value )
Shock Resistance	Malfunction: 10G(11ms) ; Destructive: 100G(6ms)
Vibration Resistance	Malfunction: 10 to 55 Hz. at Double Amplitude of 1.5 mm
	Destructive: 10 to 55 Hz. at Double Amplitude of 1.5 mm
Operation Time	10 ms max.
Release Time	10 ms max.
Temperature Range	- 40°C ~ + 85°C
Expected Life	With operation rate 30/min.
	Mechanical - 10,000,000 operations min.
	Electrical - 100,000 operations min. at rated load.
Weight	35 grams



## FEATURES

- Plug-in/ PCB terminals are available for customer's selection.
- 60A/ 80A high current automotive relay
- 1A (1PST) contact form
- Using at automotive, direct connection with cell motors, transmission, and anti-locking braking system.



## ORDERING INFORMATION

AM3    1A    —    12    B    P  
 1            2                            3            4            5

- |                         |                               |
|-------------------------|-------------------------------|
| 1. Type                 | 4. Cover Type                 |
| 2. Contact Arrangement  | P : Cover for Plastic Bracket |
| A : 1 Form A(1PST-NO)   | B : Plastic Cover             |
| Nil : 1 Form C(1PDT)    | 5. Terminal Type              |
| 3. Coil Nominal Voltage | Nil : Standard Type           |
|                         | P : P.C.B. Terminal           |

## CONTACT RATING

1PDT	Resistive (Cos.θ = 1)	DC 14V	80A/60A
1PST-NO	Resistive (Cos.θ = 1)	DC 14V	80A

## COIL DATA(1.8W, at 25°C)

Coil Nominal Voltage (VDC)	Resistance Tol.±10% (Ohms)	Nominal Current (mA)	Maximum Pick Up Voltage (v)	Minimum Drop Out Voltage (V)
6	18	333	3.6	0.6
12	72	167	7.2	1.2
24	288	83	14.4	2.4

## DIMENSIONS (±0.2mm)

P.C.B LAYOUT  
(BOTTOM VIEW)

WIRING DIAGRAM  
(BOTTOM VIEW)

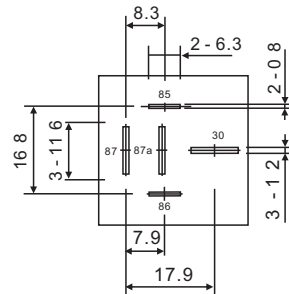
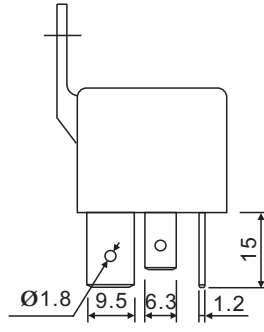
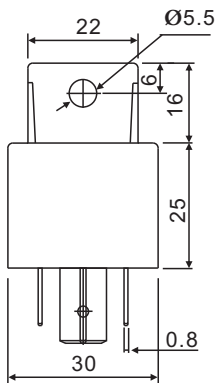

1C

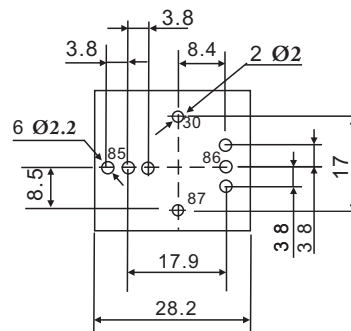
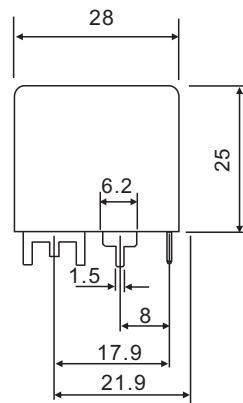
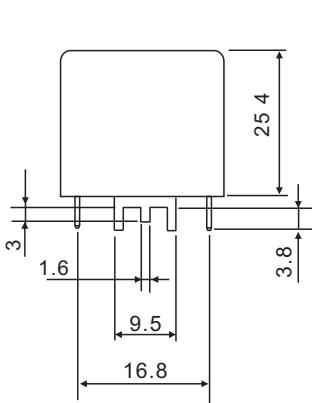
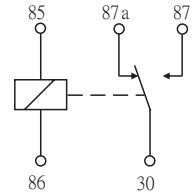

1A

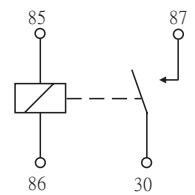

## GENERAL DATA

Insulation Resistance	100 MΩ Min. (DC 500V)
Dielectric Strength	500 VAC, 50/60Hz between contact.
	500 VAC, 50/60Hz between all elements.
Contact Material	Ag Alloy.
Contact Resistance	50 milliohms max. ( initial value )
Shock Resistance	Malfunction: 10G(11ms) ; Destructive: 100G(6ms)
Vibration Resistance	Malfunction: 10 to 55 Hz. at Double Amplitude of 1.5 mm
	Destructive: 10 to 55 Hz. at Double Amplitude of 1.5 mm
Operation Time	7 ms max.
Release Time	5 ms max.
Temperature Range	- 40°C ~ + 85°C
Expected Life	With operation rate 30/min.
	Mechanical - 10,000,000 operations min.
	Electrical - 100,000 operations min. at rated load.
Weight	41 grams

## FEATURES

- Small size, light weight.
- Low coil power consumption.
- PC board mounting.
- Suitable for automobile, automation system, electronic equipment, instrument, telecommunication facilities and remote control facilities

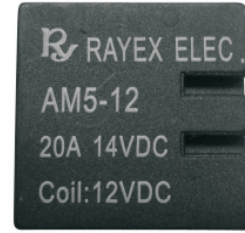

## ORDERING INFORMATION

AM5
—
12

1
2
3

- |                        |                             |
|------------------------|-----------------------------|
| 1. Type                | 3. Coil Nominal Voltage: 12 |
| 2. Contact Arrangement | 4. Coil Sensitivity         |
| Nil: 2 Form C          | Nil : Standard Type (0.6W)  |
| 2A: 2 Form A           |                             |

## CONTACT RATING

2 FORM C (SPDT)	Resistive (Cos.θ = 1)	14 VDC	20A
2 FORM A (DPST)	Resistive (Cos.θ = 1)	14 VDC	20A

## COIL DATA (0.6W at 25°C)

Coil Nominal Voltage (VDC)	Resistance Tol. ±10% (Ohms)	Nominal Current (mA)	Maximum Pick Up Voltage (V)	Minimum Drop Out Voltage (V)
	0.6W	0.6W		
12	240	50	6.9	1

## DIMENSIONS(±0.2mm)

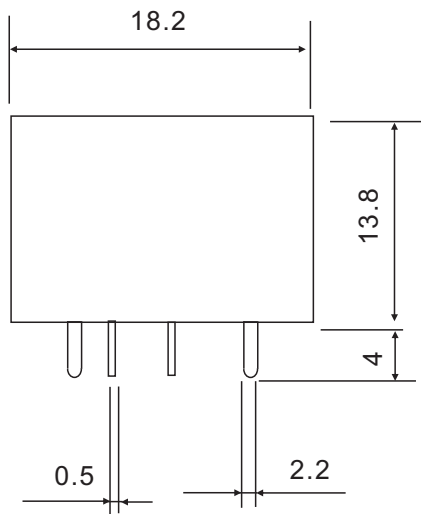

WIRING DIAGRAM  
(BOTTOM VIEW)

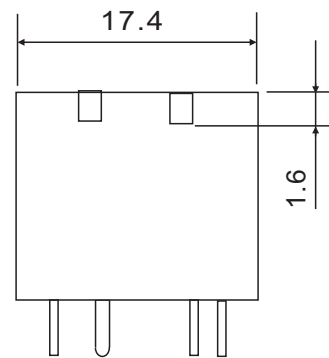
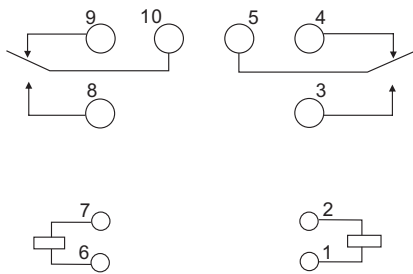

P.C.B LAYOUT  
(BOTTOM VIEW)

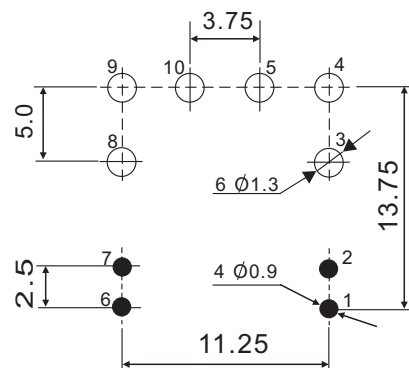

## GENERAL DATA

Insulation Resistance	100 M $\Omega$ Min. (DC 500V)
Dielectric Strength	500 VAC, 50/60Hz between contact.
	500 VAC, 50/60Hz between all elements.
Contact Material	Ag Alloy.
Contact Resistance	100 milliohms max. ( initial value )
Shock Resistance	Malfunction: 10G(11ms) ; Destructive: 100G(6ms)
Vibration Resistance	10~100Hz 100 m/s <sup>2</sup> Double Amplitude of 1.5 mm
Operation Time	10 ms max.
Release Time	5 ms max.
Temperature Range	- 40°C ~ + 85°C
Expected Life	With operation rate 30/min.
	Mechanical - 10,000,000 operations min. Electrical - 100,000 operations min. at rated load.
Weight	15 grams

## FEATURES

- Small size, light weight (4g).
- Withstands high temperature, operational under 105°C ambient temperature.
- Heavy contact load switching current up to 30A



## ORDERING INFORMATION

AM6
    
    
12
T

1
2
3
4

- |                        |                             |
|------------------------|-----------------------------|
| 1. Type                | 3. Coil Nominal Voltage: 12 |
| 2. Contact Arrangement | 4. T: Twin relay            |
| Nil: 1 Form C          |                             |
| 1A: 1 Form A           |                             |

## CONTACT RATING

1 FORM C (SPDT)	Resistive (Cos.θ = 1)	14 VDC	20A
1 FORM A (SPST)	Resistive (Cos.θ = 1)	14 VDC	20A

## COIL DATA (0.6W, at 25°C)

Coil Voltage (VDC)	Resistance Tol. ±10% (Ohms)	Nominal Current (mA)	Maximum Pick Up Voltage (V)	Minimum Drop Out Voltage (V)
12	240	50	8.4	1.2
24	960	25	16.8	2.4

## DIMENSIONS(±0.2mm)

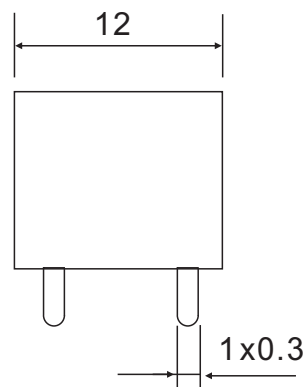
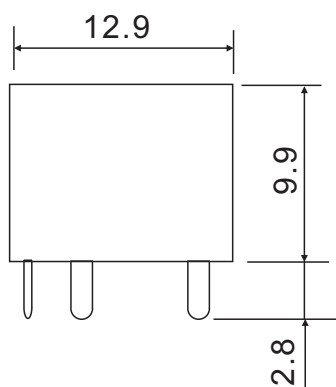

WIRING DIAGRAM  
(BOTTOM VIEW)

P.C.B LAYOUT  
(BOTTOM VIEW)

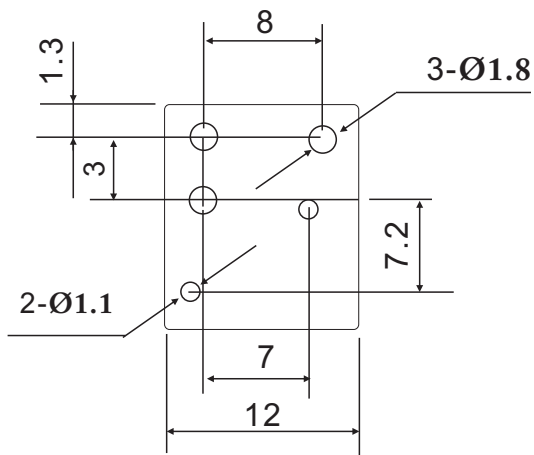
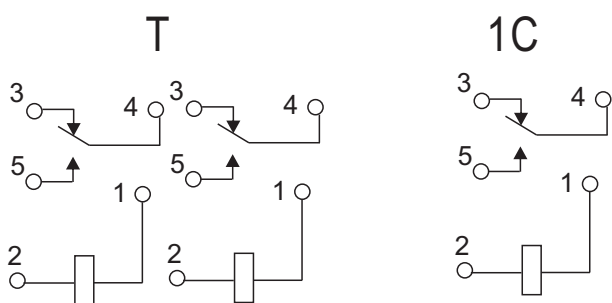

## GENERAL DATA

Insulation Resistance	1000 MΩ Min. (DC 500V)
Dielectric Strength	500 VAC, 50/60Hz between contact.
	500 VAC, 50/60Hz between all elements.
Contact Material	Ag Alloy.
Contact Resistance	100 milliohms max. ( initial value )
Shock Resistance	300m/s <sup>2</sup> 6ms
Vibration Resistance	10~500Hz double amplitude 1.27 mm 60m/s <sup>2</sup>
Temperature Range	- 40°C ~ + 105°C
Expected Life	With operation rate 30/min.
	Mechanical - 10,000,000 operations min. Electrical - 100,000 operations min. at rated load.
Weight	4 grams

## FEATURES

- Small size. light weight.
  - Low coil consumption.
  - Switching capacity up to 25A motor lock load
  - High performance PCB relay
- Suitable for household electrical appliance. automation system

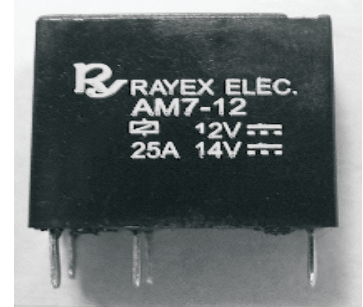

## ORDERING INFORMATION

AM7 — 12 —     
1                      2                      3

- |                         |                      |  |
|-------------------------|----------------------|--|
| 1. Type                 | 3.. Coil Sensitivity |  |
| 2. Coil Nominal Voltage | Nil : 0.8W           |  |
|                         | S : 0.64W            |  |

## CONTACT RATING

1 FORM C (SPDT)	Resistive (Cos.θ = 1)	14 VDC	25A
-----------------	-----------------------	--------	-----

## COIL DATA(0.64W,0.8W, at 25°C)

Coil Nominal Voltage (VDC)	Resistance Tol.±10% (Ohms)		Nominal Current (mA)		Maximum Pick Up Voltage (V)	Minimum Drop Out Voltage (V)
	0.8W	0.64W	0.8W	0.64W		
12	180	240	66.7	53.3	7.2	1.2
24	720	900	33.3	26.7	14.4	2.4

## DIMENSIONS(±0.2mm)

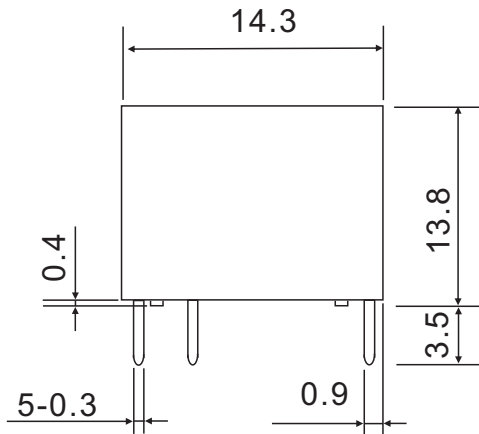

WIRING DIAGRAM  
(BOTTOM VIEW)

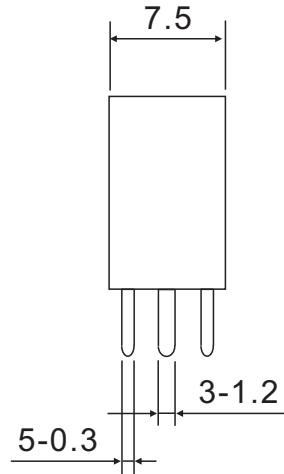
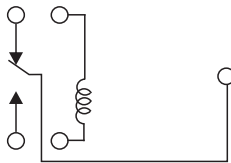

P.C.B LAYOUT  
(BOTTOM VIEW)

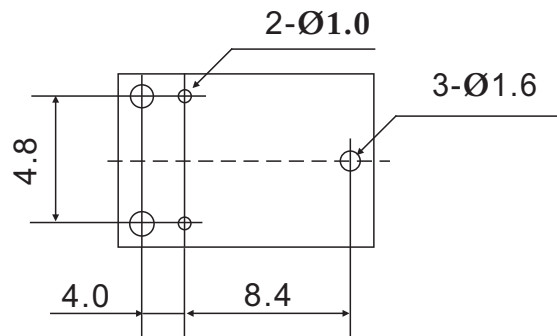

## GENERAL DATA

Insulation Resistance	100 MΩ Min. (DC 500V)
Dielectric Strength	500 VAC, 50/60Hz between contact.
	1,000 VAC, 50/60Hz between all elements.
Contact Material	Ag Alloy.
Contact Resistance	100 milliohms max. ( initial value )
Shock Resistance	Malfunction: 10G(11ms) ; Destructive: 100G(6ms)
Vibration Resistance	10Hz~500Hz Acceleration:43.1m/s <sup>2</sup>
Operation Time	10 ms max.
Release Time	5 ms max.
Temperature Range	- 40°C ~ 105°C
Expected Life	With operation rate 30/min.
	Mechanical - 10,000,000 operations min. Electrical - 100,000 operations min. at rated load.
Weight	4.1 grams



## FEATURES

- Open-frame and plastic sealed types
- European and USA footprints are available to meet international standards
- 1A(1PST) and 1C(1PDT) contact arrangement

Using at automotive, control industrial , Domestic appliances, heavy loads, etc.



## ORDERING INFORMATION

LA      12 F      W  
 1      2      3      4      5      6

- |                        |                         |                 |
|------------------------|-------------------------|-----------------|
| 1. Type                | 3. Coil Nominal Voltage | 6. Enclosure    |
| 2. Contact Arrangement | 4. Pin Position         | Nil : Open Type |
| Nil: 1 Form C          | F : USA footprint       | W : Sealed Type |
| 1A: 1 Form A           | E : European footprint  |                 |
| 1B: 1 Form B           | 5. Coil Sensitivity     |                 |
| 2A: 1PDM               | Nil : 1.6W              |                 |
| 2B: 1PDB               | S : 1.2W                |                 |

## CONTACT RATING

1PDT	Resistive (Cos.θ = 1)	DC 14V	40A/30A
1PDM	Resistive (Cos.θ = 1)	DC 14V	2 x 20A

## COIL DATA(1.2W,1.6W, at 25°C)

Coil Nominal Voltage (VDC)	Resistance Tol.±10% (Ohms)		Nominal Current (mA)		Maximum Pick Up Voltage (V)		Minimum Drop Out Voltage (V)
	1.6W	1.2W	1.6W	1.2W	1.6W	1.2W	
6	22.5	30	266.7	200	4.2	4.5	0.6
9	50.6	67.5	177.9	133.3	6.3	6.75	0.9
12	90	120	133.3	100	8.4	9.0	1.2
24	360	480	66.7	50	16.8	18.0	2.4

## DIMENSIONS(±0.2mm)

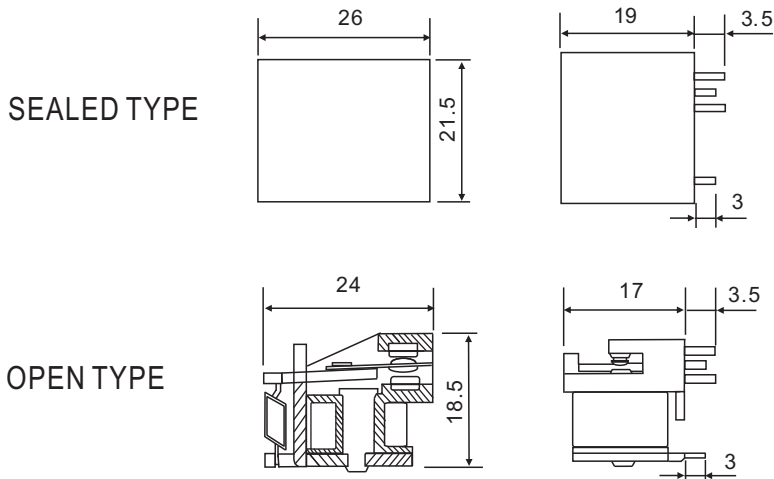

SEALED TYPE

OPEN TYPE

WIRING DIAGRAM  
(BOTTOM VIEW)

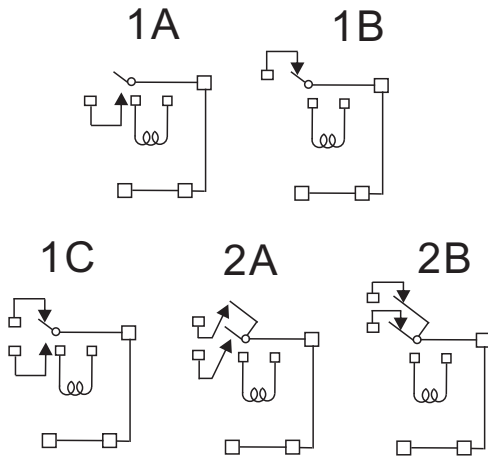

P.C.B LAYOUT  
(BOTTOM VIEW)

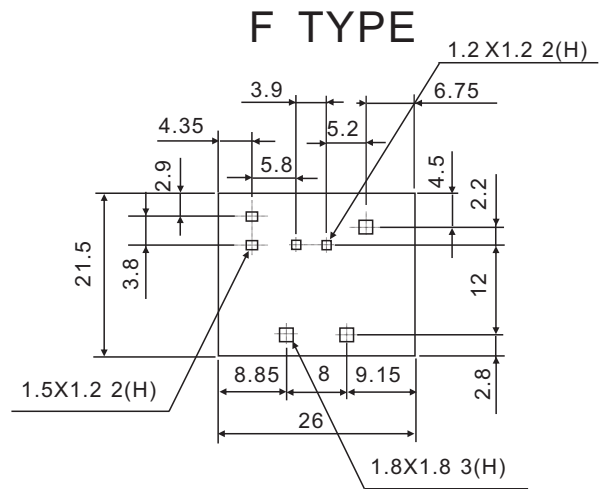

F TYPE

E TYPE

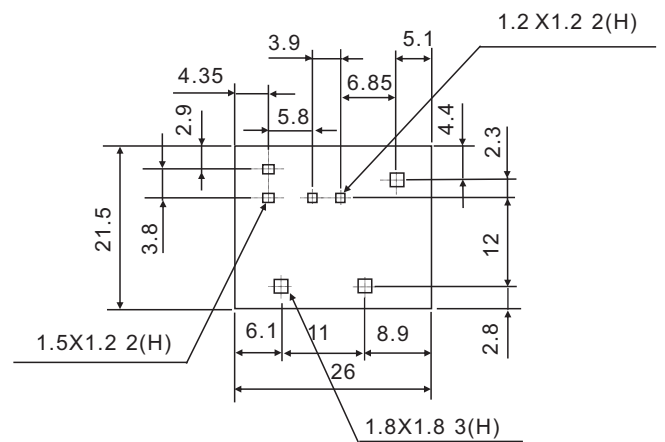

## GENERAL DATA

Insulation Resistance	100 MΩ Min. (DC 500V)
Dielectric Strength	500 VAC, 50/60Hz between contact.
	1,000 VAC, 50/60Hz between all elements.
Contact Material	Ag Alloy.
Contact Resistance	100 milliohms max. ( initial value )
Shock Resistance	Malfunction: 10G(11ms) ; Destructive: 100G(6ms)
Vibration Resistance	Malfunction: 10 to 55 Hz. at Double Amplitude of 1.5 mm
	Destructive: 10 to 55 Hz. at Double Amplitude of 1.5 mm
Operation Time	10 ms max.
Release Time	5 ms max.
Temperature Range	- 30°C ~ + 80°C
Expected Life	With operation rate 30/min.
	Mechanical - 10,000,000 operations min.
	Electrical - 100,000 operations min. at rated load.
Weight	15 grams

## FEATURES

- 1 Form C (1PDT) contact arrangement
- 6g compact lightweight structure
- High resistance for vibration and shock
- Using at automotive, security systems, etc.



## ORDERING INFORMATION

LQ
  
— 12
S

1
2
3
4

- |                        |                         |
|------------------------|-------------------------|
| 1. Type                | 3. Coil Nominal Voltage |
| 2. Contact Arrangement | 4. Coil Sensitivity     |
| Nil: 1 Form C          | Nil : 0.8W              |
| 1A: 1 Form A           | S : 0.6W                |
| 2A: 1 PDM              |                         |

## CONTACT RATING

1 FORM C (SPDT)	Resistive (Cos.θ = 1)	14 VDC	20A
1PST-DM	Resistive (Cos.θ = 1)	14 VDC	10A

## COIL DATA(0.6W,0.8W, at 25°C)

Coil Nominal Voltage (VDC)	Resistance Tol.±10% (Ohms)		Nominal Current (mA)		Maximum Pick Up Voltage (V)	Minimum Drop Out Voltage (V)
	0.8W	0.6W	0.8W	0.6W		
6	45	60	133.4	100.0	3.6	0.6
9	100	135	90.0	66.7	5.4	0.9
12	180	240	66.7	50.0	7.2	1.2
24	720	960	33.3	25.0	14.4	2.4

## DIMENSIONS(±0.2mm)

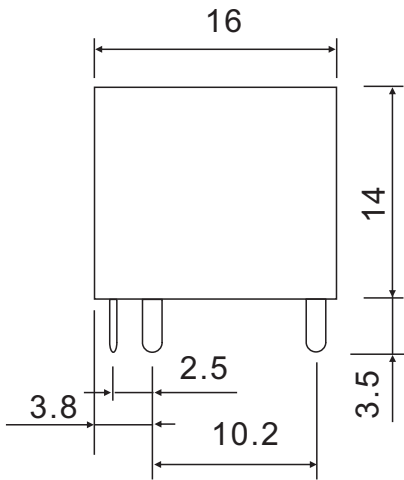

**WIRING DIAGRAM  
(BOTTOM VIEW)**

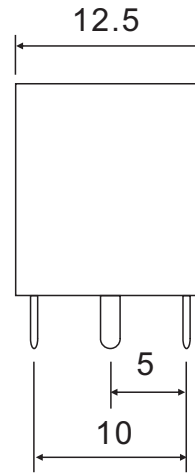

**P.C.B LAYOUT  
(BOTTOM VIEW)**

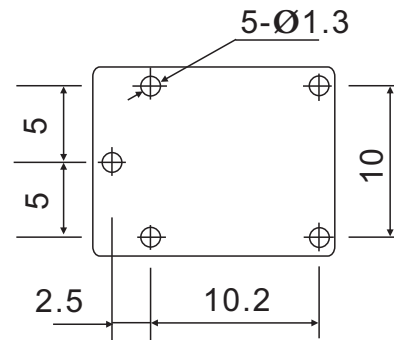
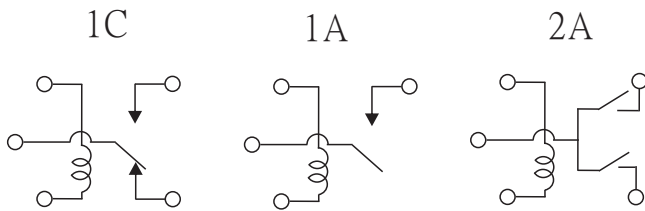

## GENERAL DATA

Insulation Resistance	100 MΩ Min. (DC 500V)
Dielectric Strength	500 VAC, 50/60Hz between contact.
	1,000 VAC, 50/60Hz between all elements.
Contact Material	Ag Alloy.
Contact Resistance	100 milliohms max. ( initial value )
Shock Resistance	Malfunction: 10G(11ms) ; Destructive: 100G(6ms)
Vibration Resistance	Malfunction: 10 to 55 Hz. at Double Amplitude of 1.5 mm
	Destructive: 10 to 55 Hz. at Double Amplitude of 1.5 mm
Operation Time	10 ms max.
Release Time	5 ms max.
Temperature Range	- 30°C ~ + 85°C
Expected Life	With operation rate 30/min.
	Mechanical - 10,000,000 operations min.
	Electrical - 100,000 operations min. at rated load.
Weight	6 grams

## FEATURES

- 30A switching use relay at ambient temperature of 85°
- Solder lug (quick connect) and PCB terminals are available for customer's selection.
- Contact form: 1 form C, 1 Form B, 1 Form A, and 2 Form A
- Using at automotives, direct connection with cell motors, transmission, and anti-locking braking system.



## ORDERING INFORMATION

LD ——— 12 F

1      2                      3      4      5      6

### 1. Type

### 2. Contact Arrangement

Nil : 1 Form C  
 1A : 1 Form A  
 1B : 1 Form B  
 2A : 1PDM  
 2AU

### 3. Coil Nominal Voltage

### 4. Cover Type

F : Cover for Steel Bracket  
 P : Cover for Plastic Bracket  
 B : Plastic Cover

### 5. Terminal Type

Nil : Standard Type  
 P : PCB Terminal

### 6. Special Mark

Nil : Standard Type.

R : Coil parallel with 1/2W resistor 820Ω for 12VDC, 3200Ω for 24VDC.  
 D1 : Coil parallel with diode 1N4007 the Positive pole "+" on # 85 terminal.  
 D2 : Coil parallel with diode 1N4007 the Negative pole "-" on # 85 terminal.

## CONTACT RATING

1PDT	Resistive (Cos.θ = 1)	DC 14V	40A/30A
1PST-DM	Resistive (Cos.θ = 1)	DC 14V	2 x 20A

## COIL DATA(1.8W, at 25°C)

Coil Nominal Voltage (VDC)	Resistance Tol.±10% (Ohms)	Nominal Current (mA)	Maximum Pick Up Voltage (V)	Minimum Drop Out Voltage (V)
5	14	357	3.5	0.5
12	80	150	8.4	1.2
24	320	75	16.8	2.4

# DIMENSIONS(±0.2mm)

F TYPE

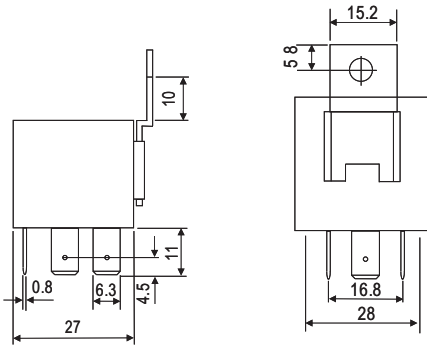

P TYPE

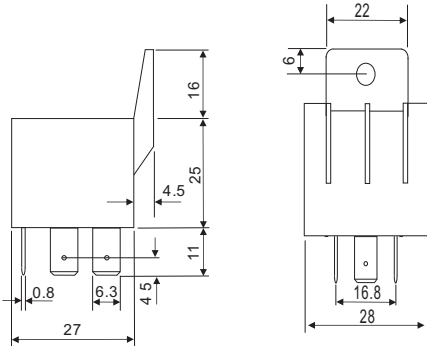

B TYPE

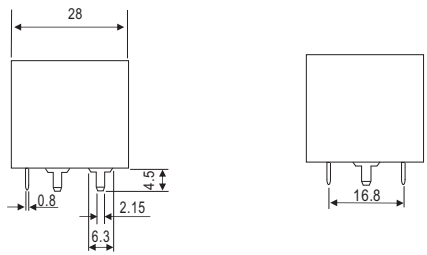

P.C.B LAYOUT  
(BOTTOM VIEW)

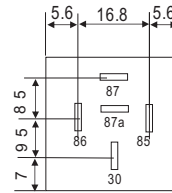
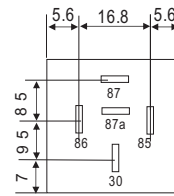
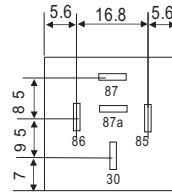

WIRING DIAGRAM  
(BOTTOM VIEW)

1C

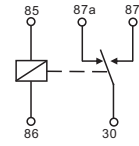

1A

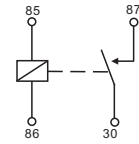

2A

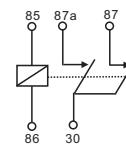

1B

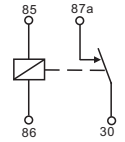

2AU

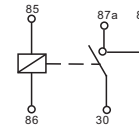

## GENERAL DATA

Insulation Resistance	50 MΩ Min. (DC 500V)
Dielectric Strength	500 VAC, 50/60Hz between contact.
	1,000 VAC, 50/60Hz between all elements.
Contact Material	Ag Alloy.
Contact Resistance	100 milliohms max. ( initial value )
Shock Resistance	Malfunction: 10G(11ms) ; Destructive: 100G(6ms)
Vibration Resistance	Malfunction: 10 to 55 Hz. at Double Amplitude of 1.5 mm
	Destructive: 10 to 55 Hz. at Double Amplitude of 1.5 mm
Operation Time	10 ms max.
Release Time	10 ms max.
Temperature Range	- 40°C ~ + 85°C
Expected Life	With operation rate 30/min.
	Mechanical - 1,000,000 operations min. Electrical - 100,000 operations min. at rated load.
Weight	32 grams

## FEATURES

- 40A switching use relay at ambient temperature of 85°
- Solder lug (quick connect) and PCB terminals are available for customer's selection.
- Contact form: 1 form C, 1 Form B, 1 Form A, and 2 Form A
- Using at automotives, direct connection with cell motors, transmission, and anti-locking braking system.

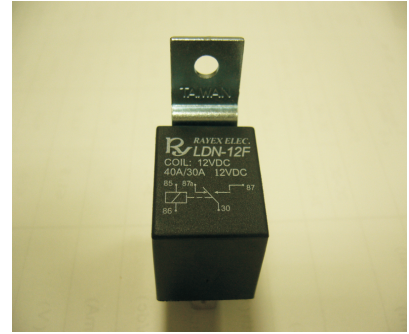

## ORDERING INFORMATION

LDN ——— 12 F

1      2                      3      4      5      6

1. Type

2. Contact Arrangement

Nil : 1 Form C  
 1A : 1 Form A  
 1B : 1 Form B  
 2A : 1PDM

3. Coil Nominal Voltage

4. Cover Type

F : Cover for Steel Bracket  
 P : Cover for Plastic Bracket  
 B : Plastic Cover

5. Terminal Type

Nil : Standard Type  
 P : PCB Terminal

6. Special Mark

Nil : Standard Type.

R : Coil parallel with 1/2W resistor 820Ω for 12VDC, 3200Ω for 24VDC.  
 D1 : Coil parallel with diode 1N4007 the Positive pole "+" on # 85 terminal.  
 D2 : Coil parallel with diode 1N4007 the Negative pole "-" on # 85 terminal.

## CONTACT RATING

1PDT	Resistive (Cos.θ = 1)	DC 14V	40A/30A
1PST-DM	Resistive (Cos.θ = 1)	DC 14V	2 x 20A

## COIL DATA(1.8W, at 25°C)

Coil Nominal Voltage (VDC)	Resistance Tol.±10% (Ohms)	Nominal Current (mA)	Maximum Pick Up Voltage (V)	Minimum Drop Out Voltage (V)
12	80	150	8.4	1.2
24	320	75	16.8	2.4

## DIMENSIONS(±0.2mm)

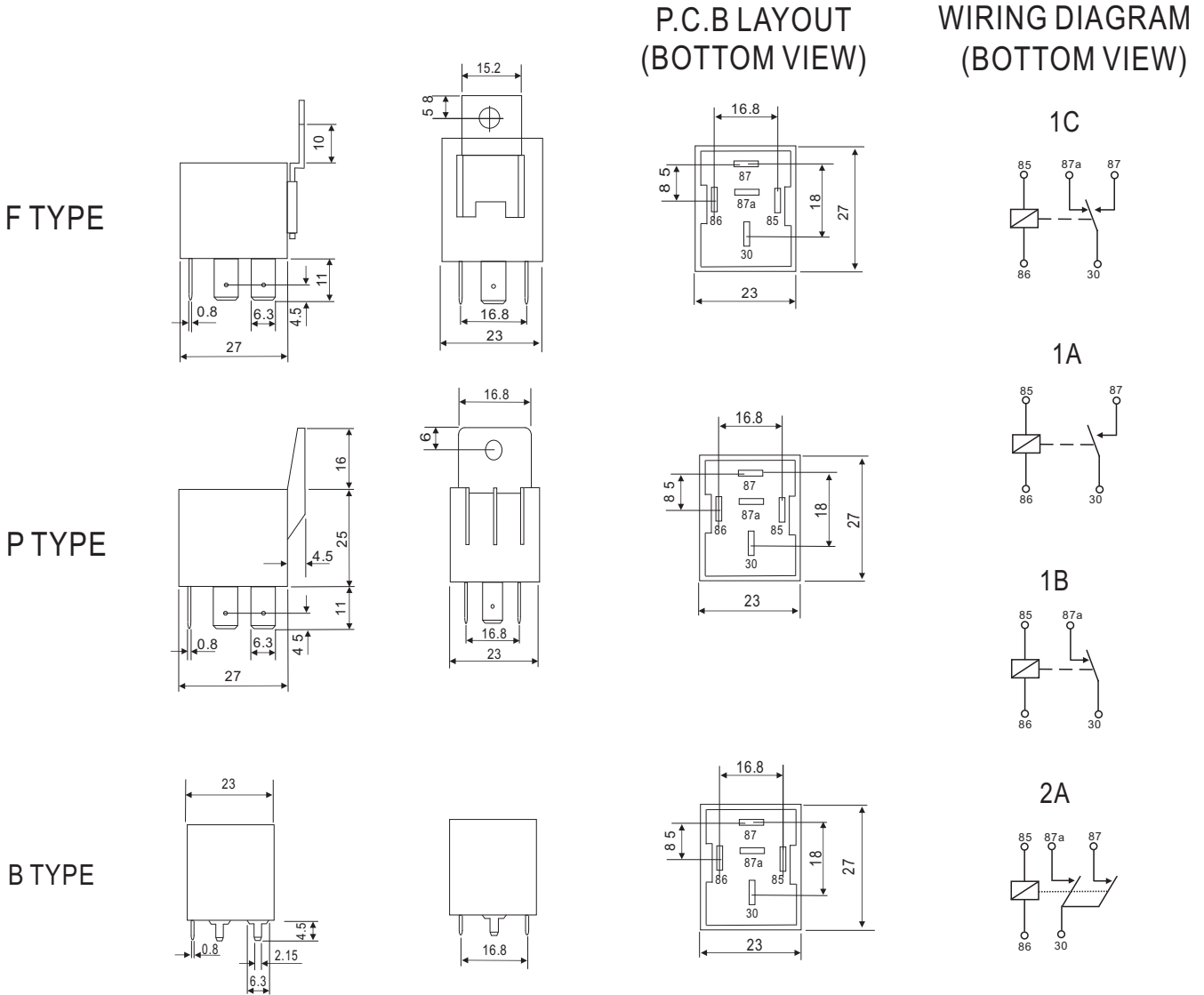

## GENERAL DATA

Insulation Resistance	50 MΩ Min. (DC 500V)
Dielectric Strength	500 VAC, 50/60Hz between contact.
	1,000 VAC, 50/60Hz between all elements.
Contact Material	Ag Alloy.
Contact Resistance	100 milliohms max. ( initial value )
Shock Resistance	Malfunction: 10G(11ms) ; Destructive: 100G(6ms)
Vibration Resistance	Malfunction: 10 to 55 Hz. at Double Amplitude of 1.5 mm
	Destructive: 10 to 55 Hz. at Double Amplitude of 1.5 mm
Operation Time	10 ms max.
Release Time	10 ms max.
Temperature Range	- 40°C ~ + 85°C
Expected Life	With operation rate 30/min.
	Mechanical - 1,000,000 operations min. Electrical - 100,000 operations min. at rated load.
Weight	33 grams





## DIMENSIONS(±0.2mm)

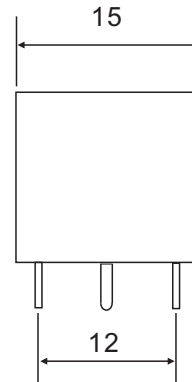
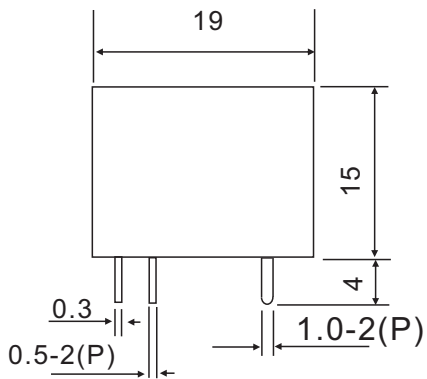

WIRING DIAGRAM  
(BOTTOM VIEW)

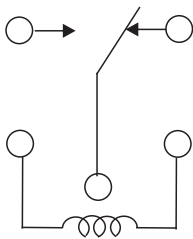

P.C.B LAYOUT  
(BOTTOM VIEW)

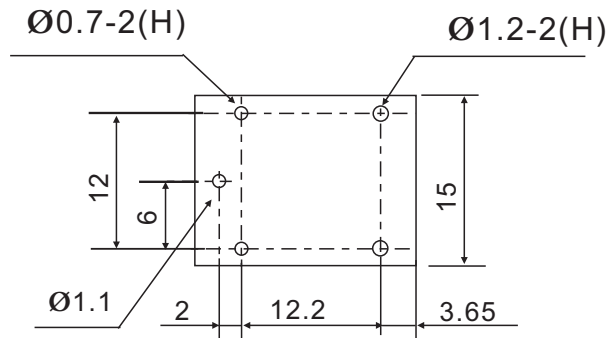

## GENERAL DATA

Insulation Resistance	100 MΩ Min. (DC 500V)
Dielectric Strength	750 VAC, 50/60Hz between contact.
	1,500 VAC, 50/60Hz between all elements.
Contact Material	Ag Alloy.
Contact Resistance	100 milliohms max. ( initial value )
Shock Resistance	Malfunction: 10G(11ms) ; Destructive: 100G(6ms)
Vibration Resistance	Malfunction: 10 to 55 Hz. at Double Amplitude of 1.5 mm
	Destructive: 10 to 55 Hz. at Double Amplitude of 1.5 mm
Operation Time	8 ms max.
Release Time	8 ms max.
Temperature Range	- 30°C ~ + 85°C
Expected Life	With operation rate 30/min.
	Mechanical - 10,000,000 operations min.
	Electrical - 100,000 operations min. at rated load.
Weight	9 grams



## DIMENSIONS(±0.2mm)

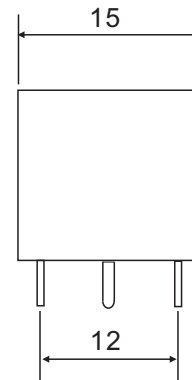
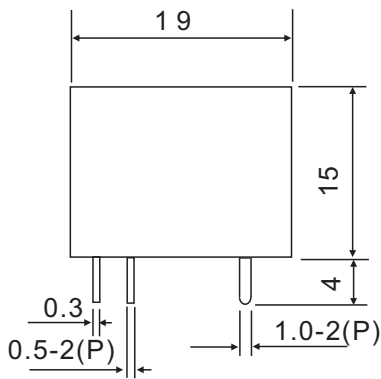

WIRING DIAGRAM  
(BOTTOM VIEW)

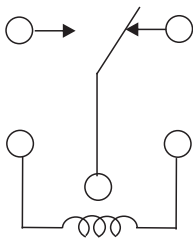

P.C.B LAYOUT  
(BOTTOM VIEW)

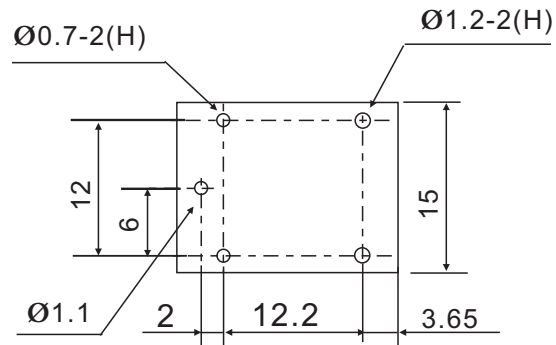

## GENERAL DATA

Insulation Resistance	100 M $\Omega$ Min. (DC 500V)
Dielectric Strength	750 VAC, 50/60Hz between contact.
	1,500 VAC, 50/60Hz between all elements.
Contact Material	Ag Alloy.
Contact Resistance	100 milliohms max. ( initial value )
Shock Resistance	Malfunction: 10G(11ms) ; Destructive: 100G(6ms)
Vibration Resistance	Malfunction: 10 to 55 Hz. at Double Amplitude of 1.5 mm
	Destructive: 10 to 55 Hz. at Double Amplitude of 1.5 mm
Operation Time	8 ms max.
Release Time	8 ms max.
Temperature Range	- 30°C ~ + 85°C
Expected Life	With operation rate 30/min.
	Mechanical - 10,000,000 operations min.
	Electrical - 100,000 operations min. at rated load.
Weight	9 grams



## DIMENSIONS(±0.2mm)

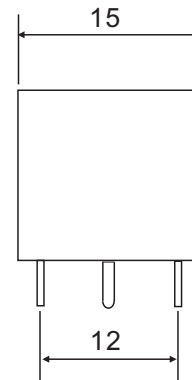
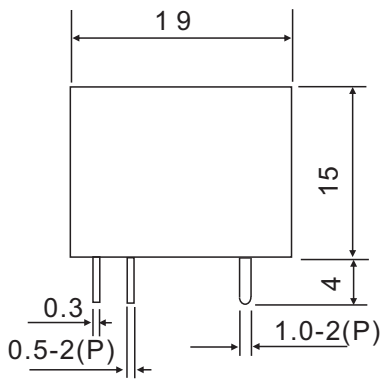

WIRING DIAGRAM  
(BOTTOM VIEW)

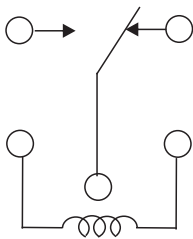

P.C.B LAYOUT  
(BOTTOM VIEW)

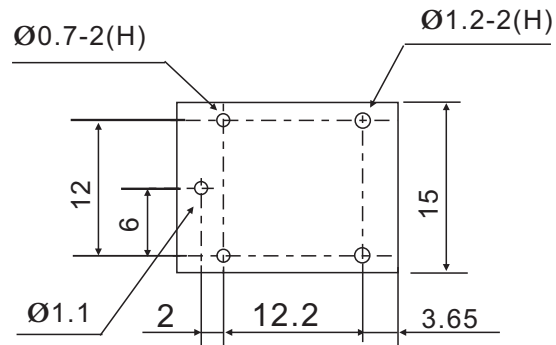

## GENERAL DATA

Insulation Resistance	100 M $\Omega$ Min. (DC 500V)
Dielectric Strength	750 VAC, 50/60Hz between contact.
	1,500 VAC, 50/60Hz between all elements.
Contact Material	Ag Alloy.
Contact Resistance	100 milliohms max. ( initial value )
Shock Resistance	Malfunction: 10G(11ms) ; Destructive: 100G(6ms)
Vibration Resistance	Malfunction: 10 to 55 Hz. at Double Amplitude of 1.5 mm
	Destructive: 10 to 55 Hz. at Double Amplitude of 1.5 mm
Operation Time	8 ms max.
Release Time	8 ms max.
Temperature Range	- 30°C ~ + 85°C
Expected Life	With operation rate 30/min.
	Mechanical - 10,000,000 operations min.
	Electrical - 100,000 operations min. at rated load.
Weight	9 grams



## DIMENSIONS(±0.2mm)

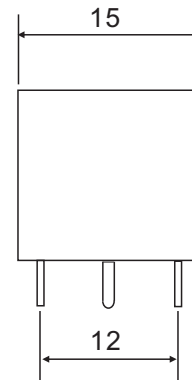
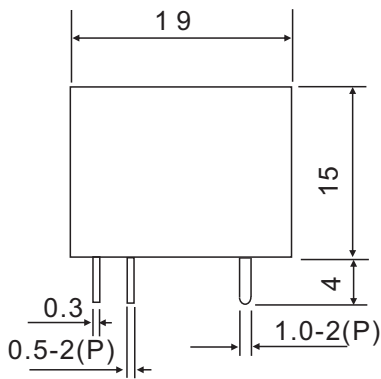

WIRING DIAGRAM  
(BOTTOM VIEW)

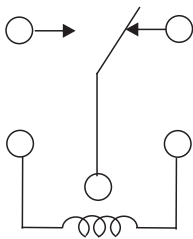

P.C.B LAYOUT  
(BOTTOM VIEW)

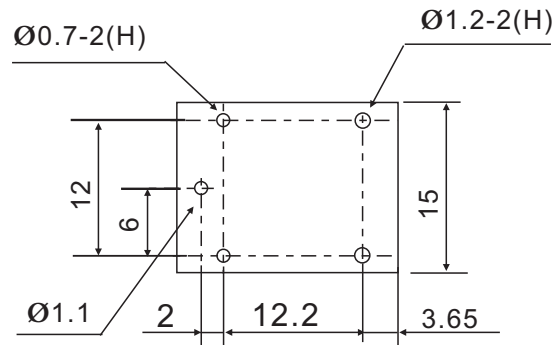

## GENERAL DATA

Insulation Resistance	100 M $\Omega$ Min. (DC 500V)
Dielectric Strength	750 VAC, 50/60Hz between contact.
	1,500 VAC, 50/60Hz between all elements.
Contact Material	Ag Alloy.
Contact Resistance	100 milliohms max. ( initial value )
Shock Resistance	Malfunction: 10G(11ms) ; Destructive: 100G(6ms)
Vibration Resistance	Malfunction: 10 to 55 Hz. at Double Amplitude of 1.5 mm
	Destructive: 10 to 55 Hz. at Double Amplitude of 1.5 mm
Operation Time	8 ms max.
Release Time	8 ms max.
Temperature Range	- 30°C ~ + 85°C
Expected Life	With operation rate 30/min.
	Mechanical - 10,000,000 operations min.
	Electrical - 100,000 operations min. at rated load.
Weight	9 grams



## FEATURES

- Up to 15A for exclusive automobile control relay switching box use
- Open-frame and sealed type are available
- Contact form: 1 form A, 2 form A  
Using at automotive, security systems, etc

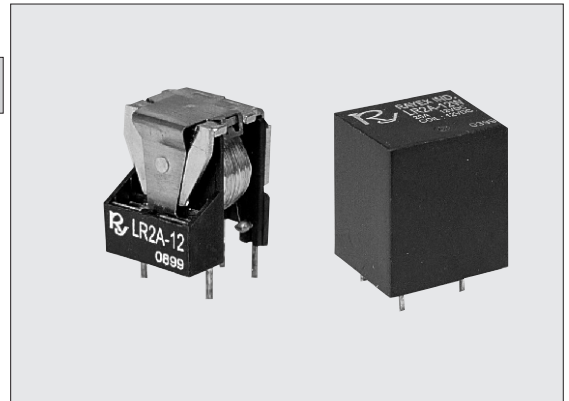

## ORDERING INFORMATION

LR    1A    —    12    W  
 1        2                    3        4

- |                        |                         |
|------------------------|-------------------------|
| 1. Type                | 3. Coil Nominal Voltage |
| 2. Contact Arrangement | 4. Enclosure            |
| 1A : SPNO              | Nil : Open Type         |
| 2A : SPDM              | W : Sealed Type         |

## CONTACT RATING

SPST-NO	Resistive (Cos.θ = 1)	DC 14 V	15A
SPST-DM	Resistive (Cos.θ = 1)	DC 14 V	2 x 10A

## COIL DATA(1.1W, at 25°C )

Coil Nominal Voltage (VDC)	Resistance Tol.±10% (Ohms )	Nominal Current (mA)	Maximum Pick Up Voltage (V)	Minimum Drop Out Voltage (V)
6	33	182	3.6	0.6
12	130	92	7.2	1.2
24	520	46	14.4	2.4

## DIMENSIONS(±0.2mm)

SEALED TYPE

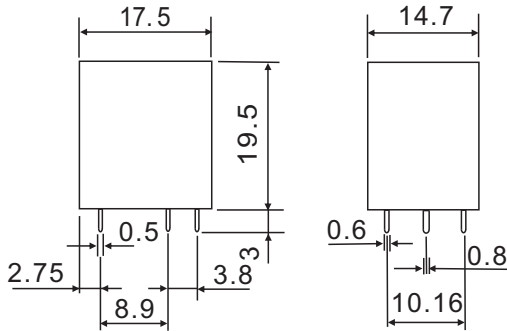

OPEN TYPE

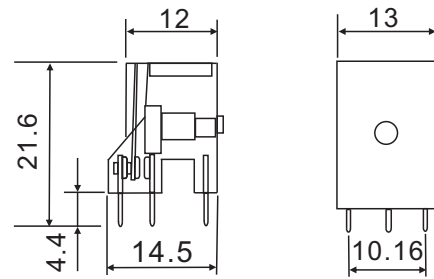

WIRING DIAGRAM  
(BOTTOM VIEW)

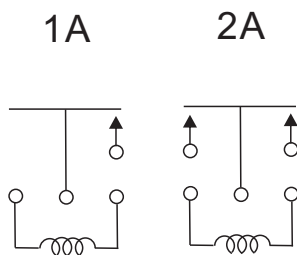

P.C.B LAYOUT  
(BOTTOM VIEW)

SEALED TYPE

OPEN TYPE

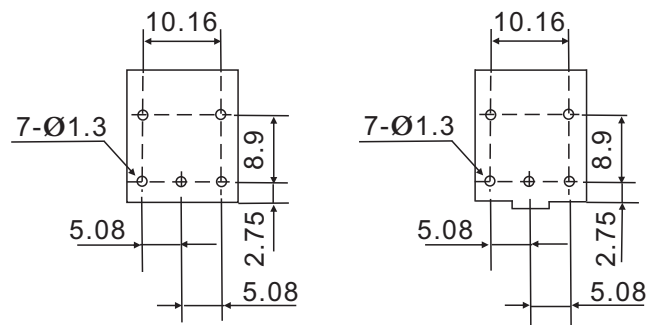

## GENERAL DATA

Insulation Resistance	100 MΩ Min. (DC 500V)
Dielectric Strength	750 VAC, 50/60Hz between contact.
	500 VAC, 50/60Hz between all elements.
Contact Material	Ag Alloy.
Contact Resistance	100 milliohms max. ( initial value )
Shock Resistance	Malfunction: 10G(11ms) ; Destructive: 100G(6ms)
Vibration Resistance	Malfunction: 10 to 55 Hz. at Double Amplitude of 1.5 mm
	Destructive: 10 to 55 Hz. at Double Amplitude of 1.5 mm
Operation Time	6 ms max.
Release Time	3 ms max.
Temperature Range	- 40°C ~ + 85°C
Expected Life	With operation rate 30/min.
	Mechanical - 10,000,000 operations min.
	Electrical - 100,000 operations min. at rated load.
Weight	12 grams



RAYEX ELEC.

# LB SERIES

## FEATURES

- High performance power relay
- PCB terminal and solder lug terminal and flanged case are available
- LED version are available
- UL, CUL, TUV, and CE approved
- Using at control equipment, vending machine, cooking appliances, office machine, domestic appliances, etc.

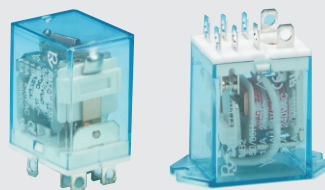

UL FILE NO.: E131959  
 CUL FILE NO.: E131959  
 TUV FILE NO.: R9956267

## ORDERING INFORMATION

LB1 N — 12 D F S  
 1 2 3 4 5 6

### 1. Type

- LB1(1PDT) : 15A
- LB2(2PDT) : 12A
- LB2H(2PDT) : 10A
- LB4H(4PDT) : 5A

### 2. LED

- Nil : Without LED
- N : With LED

### 3. Coil Nominal Voltage

- 4. Coil Nominal Voltage Type
- D: DC
- A: AC

### 5. Cover Type

- Nil : Standard Type
- F : Flange Cover

### 6. Terminal Type

- S : Solder Lug / Plug-In Terminal
- P : PCB Terminal

## COIL DATA(at 25°C)

AC 1.2VA				DC 0.9-1.1W				
Coil Nominal Voltage (50/60Hz)	Resistance Tol.±10% (Ohms)	Maximum Pick Up Voltage (V)	Minimum Drop Out Voltage (V)	Coil Nominal Voltage (VDC)	Resistance Tol.±10% (Ohms)	Nominal Current (mA)	Maximum Pick Up Voltage (V)	Minimum Drop Out Voltage (V)
6	10	4.8	1.8	6	40	150	4.5	0.6
12	45	9.6	3.6	12	160	75	9.0	1.2
24	160	19.2	7.2	24	650	37	18.0	2.4
48	670	38.4	14.4	48	2,600	19	36.0	4.8
100/110	3,900	88.0	33.0	100/110	11,000	9	82.5	11.0
220/240	16,000	176.0	66.0					

## CONTACT RATING

LB1 TYPE	Resistive (Cos.θ = 1)	AC 240V / DC 30V	15A	UL
		AC 240V / DC 24V	15A	TUV
	Inductive (Cos.θ = 0.4)	AC 240V	8A	TUV
LB2 TYPE	Resistive (Cos.θ = 1)	AC 240V / DC 30V	12A	UL
		AC 240V / DC 24V	10A	TUV
	Inductive (Cos.θ = 0.4)	AC 240V	5A	TUV
LB2H TYPE	Resistive (Cos.θ = 1)	AC 240V / DC 30V	10A	UL
		AC 240V / DC 24V	10A	TUV
	Inductive (Cos.θ = 0.4)	AC 240V	5A	TUV
LB4H TYPE	Resistive (Cos.θ = 1)	AC 240V / DC 30V	5A	UL
		AC 240V / DC 24V	5A	TUV
	Inductive (Cos.θ = 0.4)	AC 240V	3A	TUV

## DIMENSIONS(±0.2mm)

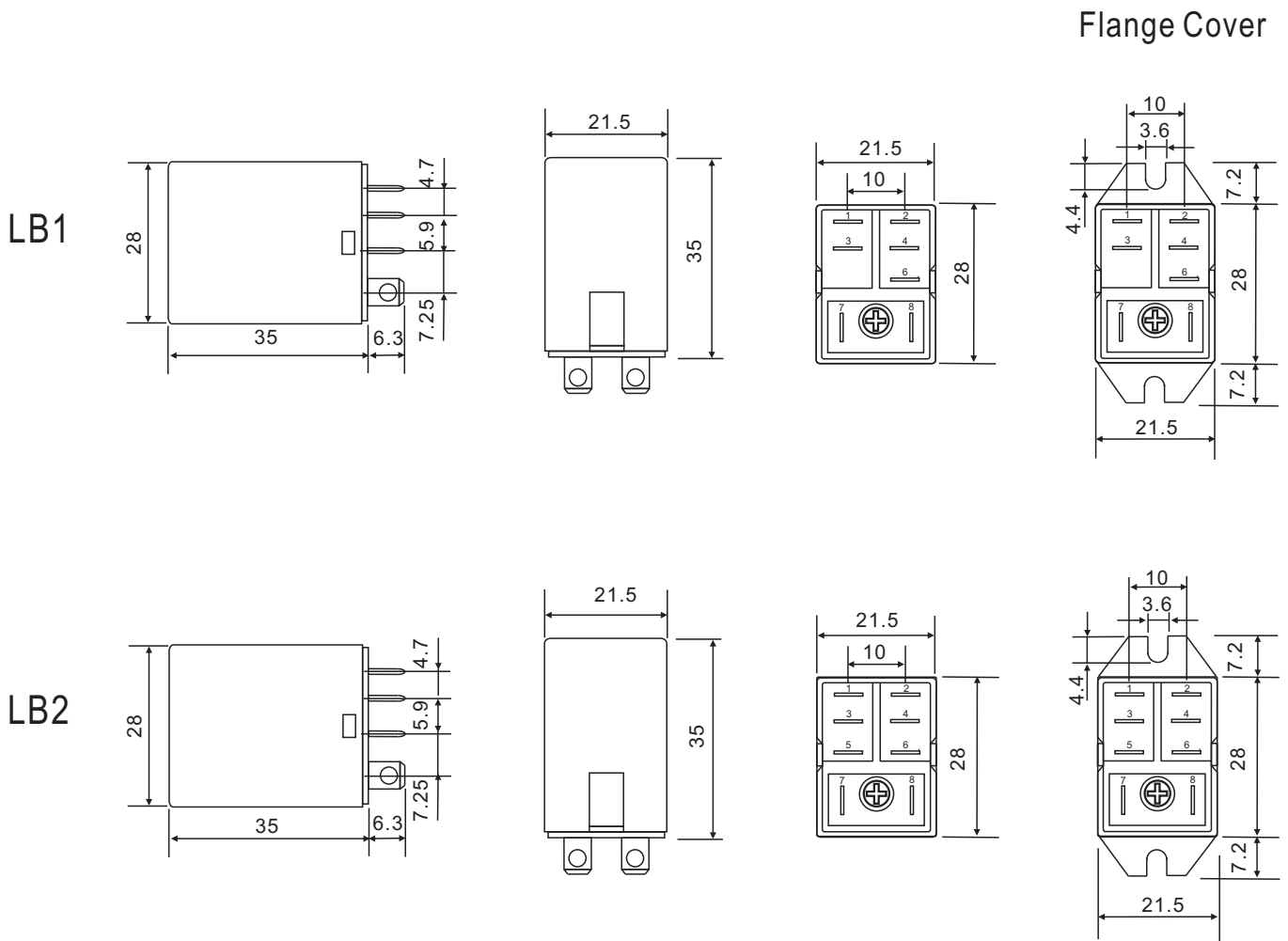

# DIMENSIONS(±0.2mm)

## Flange Cover

LB2H

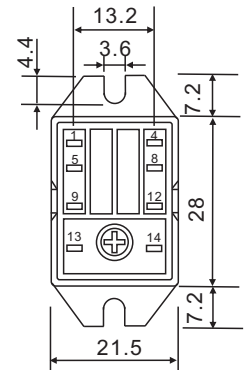
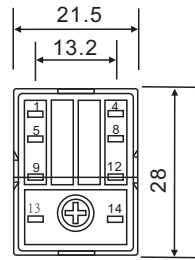
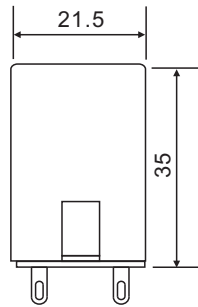
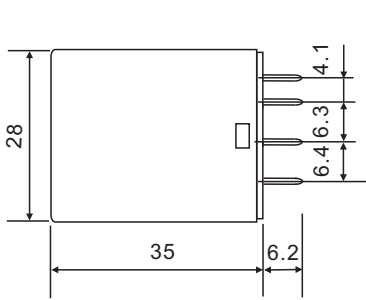

LB4H

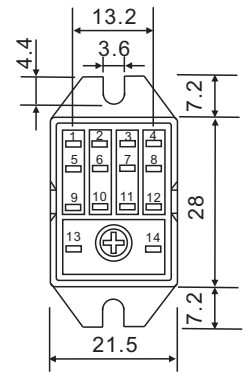
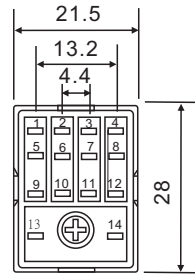
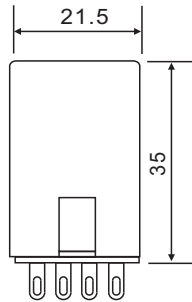
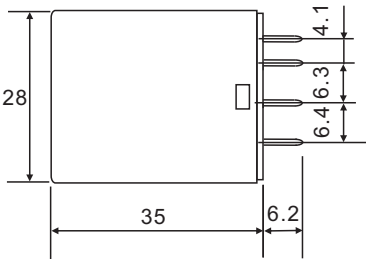

# DRILLING PLAN

LB1

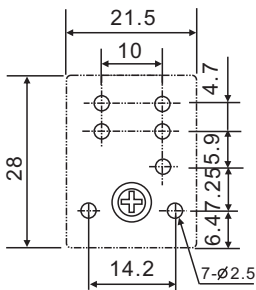

LB2

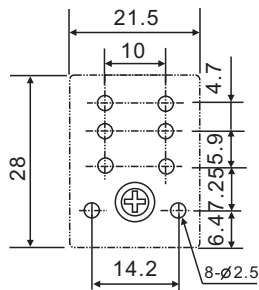

LB2H

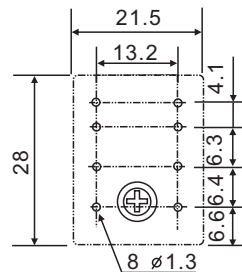

LB4H

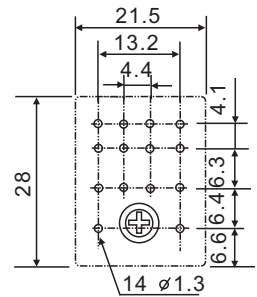

## WRING DIAGRAM

LB1

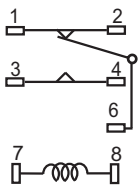

LB2

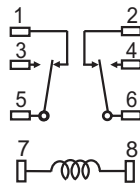

LB2H

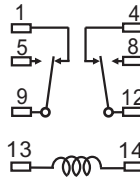

LB4H

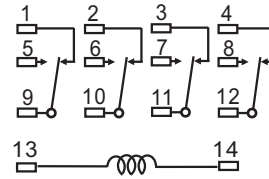

## TERMINAL TYPE(±0.2mm)

SOLDER LUG/PLUG-IN

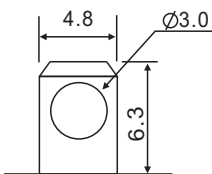

LB1, LB2

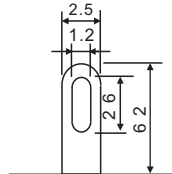

LB2H, LB4H

PRINTED CIRCUIT

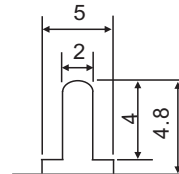

## GENERAL DATA

Insulation Resistance	1,500 MΩ Min. (DC 500V)
Dielectric Strength	750 VAC, 50/60Hz between contact.
	1,500 VAC, 50/60Hz between all elements.
Contact Material	Ag Alloy.
Contact Resistance	100 milliohms max. ( initial value )
Shock Resistance	Malfunction: 10G(11ms) ; Destructive: 100G(6ms)
Vibration Resistance	Malfunction: 10 to 55 Hz. at Double Amplitude of 1.5 mm
	Destructive: 10 to 55 Hz. at Double Amplitude of 1.5 mm
Operation Time	15 ms max.
Release Time	15 ms max.
Temperature Range	- 40°C ~ + 60°C
Expected Life	With operation rate 30/min.
	Mechanical - 10,000,000 operations min.
	Electrical - 100,000 operations min. at rated load.
Weight	37 grams

## FEATURES

- High performance power relay
- PCB terminal and solder lug terminal and flanged case are available
- LED version are available
- UL, CUL, TUV, and CE approved
- Using at control equipment, vending machine, cooking appliances, office machine, domestic appliances, etc.

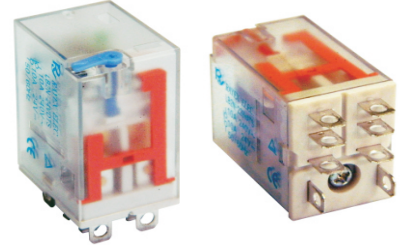

UL, CUL FILE NO.: E131959  
TUV FILE NO.: R9956267

## ORDERING INFORMATION

**LB2** **N** — **12** **D** **T** **S**

1      2                      3      4      5      6

1. Type

LB2(2PDT) : 10A  
LB2H(2PDT) : 10A  
LB4H(4PDT) : 5A

2. LED

Nil : Without LED  
N : With LED

3. Coil Nominal Voltage

4. Coil Nominal Voltage Type  
D: DC  
A: AC

5. Cover Type

T : Test button

6. Terminal Type

S : Solder Lug / Plug-In Terminal

## COIL DATA(at 25°C)

AC 1.2VA				DC 0.9-1.1W				
Coil Nominal Voltage (50/60Hz)	Resistance Tol.±10% (Ohms)	Maximum Pick Up Voltage (V)	Minimum Drop Out Voltage (V)	Coil Nominal Voltage (VDC)	Resistance Tol.±10% (Ohms)	Nominal Current (mA)	Maximum Pick Up Voltage (V)	Minimum Drop Out Voltage (V)
6	10	4.8	1.8	6	40	150	4.5	0.6
12	45	9.6	3.6	12	160	75	9.0	1.2
24	160	19.2	7.2	24	650	37	18.0	2.4
48	670	38.4	14.4	48	2,600	19	36.0	4.8
100/110	3,900	88.0	33.0	100/110	11,000	9	82.5	11.0
220/240	16,000	176.0	66.0					

## CONTACT RATING

LB2-T TYPE	Resistive (Cos.θ = 1)	AC 240V / DC 30V	12A	UL
		AC 240V / DC 24V	10A	TUV
	Inductive (Cos.θ = 0.4)	AC 240V	5A	TUV
LB2H-T TYPE	Resistive (Cos.θ = 1)	AC 240V / DC 30V	10A	UL
		AC 240V / DC 24V	10A	TUV
	Inductive (Cos.θ = 0.4)	AC 240V	5A	TUV
LB4H-T TYPE	Resistive (Cos.θ = 1)	AC 240V / DC 30V	5A	UL
		AC 240V / DC 24V	5A	TUV
	Inductive (Cos.θ = 0.4)	AC 240V	3A	TUV

## DIMENSIONS(±0.2mm)

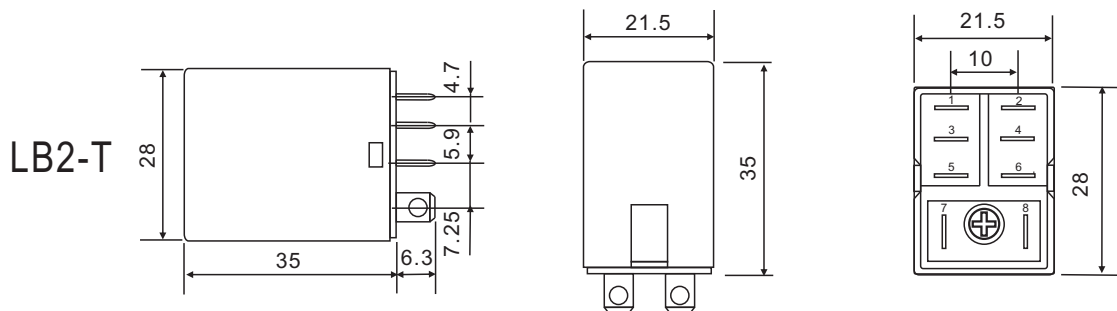



# DIMENSIONS(±0.2mm)

LB2H-T

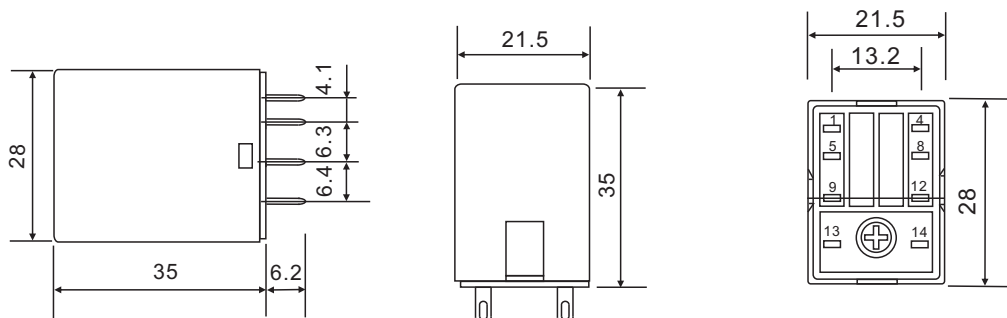

LB4H-T

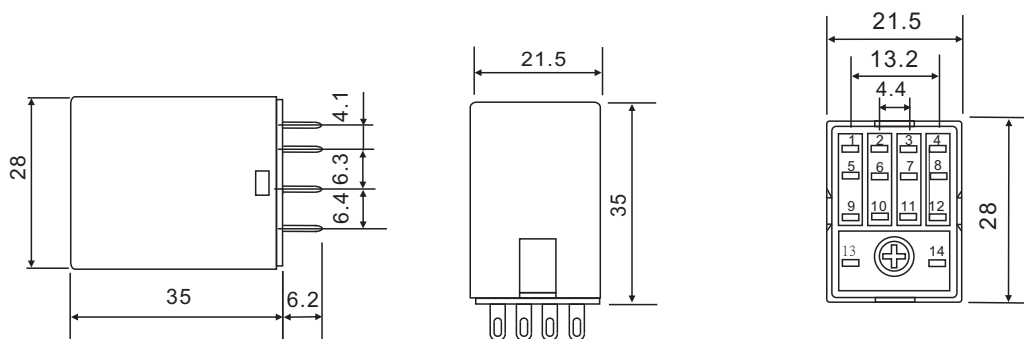

# DRILLING PLAN

LB2-T

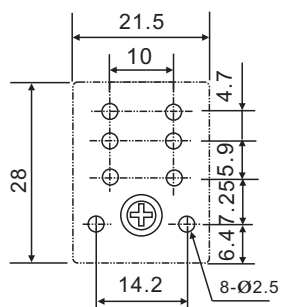

LB2H-T

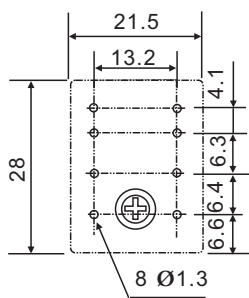

LB4H-T

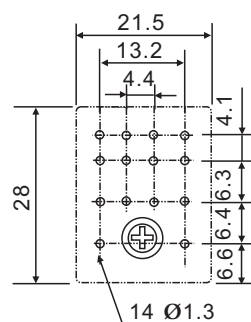

## WRING DIAGRAM

LB2-T

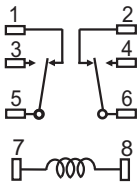

LB2H-T

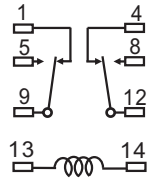

LB4H-T

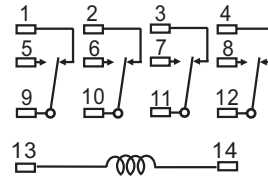

## TERMINAL TYPE(±0.2mm)

### SOLDER LUG/PLUG-IN

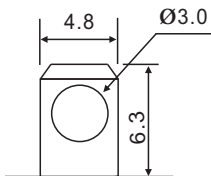

LB1, LB2

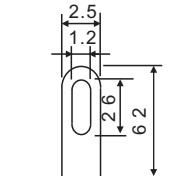

LB2H, LB4H

## GENERAL DATA

Insulation Resistance	1,500 MΩ Min. (DC 500V)
Dielectric Strength	750 VAC, 50/60Hz between contact.
	1,500 VAC, 50/60Hz between all elements.
Contact Material	Ag Alloy.
Contact Resistance	100 milliohms max. ( initial value )
Shock Resistance	Malfunction: 10G(11ms) ; Destructive: 100G(6ms)
Vibration Resistance	Malfunction: 10 to 55 Hz. at Double Amplitude of 1.5 mm
	Destructive: 10 to 55 Hz. at Double Amplitude of 1.5 mm
Operation Time	15 ms max.
Release Time	15 ms max.
Temperature Range	- 40°C ~ + 60°C
Expected Life	With operation rate 30/min.
	Mechanical - 10,000,000 operations min. Electrical - 100,000 operations min. at rated load.
Weight	37 grams



## CONTACT RATING

LY4 TYPE	Resistive (Cos.θ = 1)	AC 250V/28V	10A
----------	-----------------------	-------------	-----

## DIMENSIONS(±0.2mm)

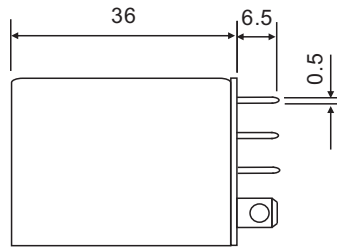
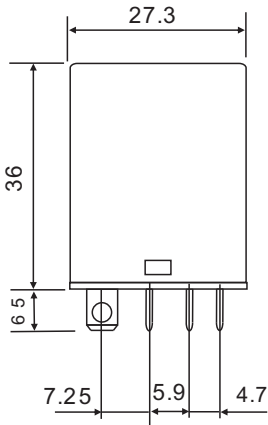

### P.C.B LAYOUT (BOTTOM VIEW)

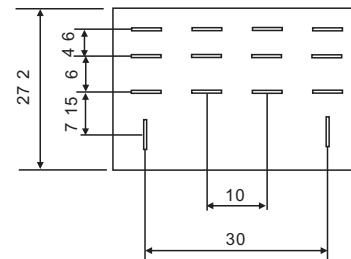

### WIRING DIAGRAM (BOTTOM VIEW)

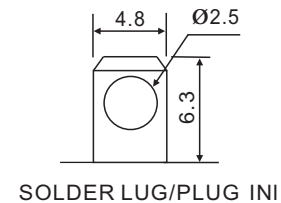
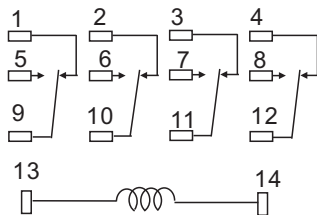

## GENERAL DATA

Insulation Resistance	100 MΩ Min. (DC 500V)
Dielectric Strength	1,000 VAC, 50/60Hz between contact.
	1,500 VAC, 50/60Hz between all elements.
Contact Material	Ag Alloy.
Contact Resistance	100 milliohms max. ( initial value )
Shock Resistance	Malfunction: 10G(11ms) ; Destructive: 100G(6ms)
Vibration Resistance	Malfunction: 10 to 55 Hz. at Double Amplitude of 1.5 mm
	Destructive: 10 to 55 Hz. at Double Amplitude of 1.5 mm
Operation Time	25 ms max.
Release Time	25 ms max.
Temperature Range	- 40°C ~ + 55°C
Expected Life	With operation rate 30/min.
	Mechanical - 10,000,000 operations min.
	Electrical - 100,000 operations min. at rated load.
Weight	Ly4 Type: 70 grams

## FEATURES

- Industry standard octal-type termination for quick installation.
- Contact rating up to 10A/250VAC

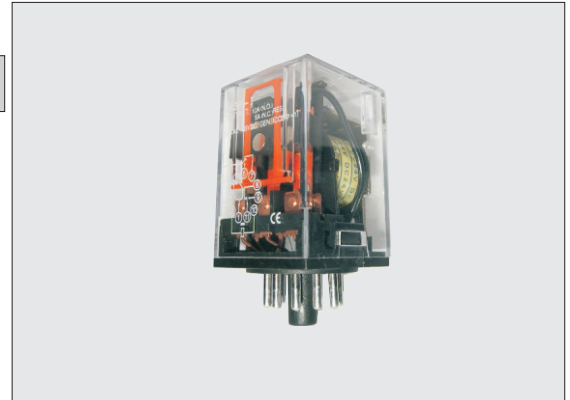

## ORDERING INFORMATION

**MK**   **2**   —   **D**  
 1        2                      3        4

- |                         |                              |
|-------------------------|------------------------------|
| 1. Type                 | 4. Coil Nominal Voltage Type |
| 2.2:2PDT(2PI)           | D: DC                        |
| 3:3PDT(3P5I)            | A: AC                        |
| 3. Coil Nominal Voltage |                              |

## COIL DATA(at 25°C)

AC 2.8VA				DC 1.6W				
Coil Nominal Voltage (50/60Hz)	Resistance Tol.±10% (Ohms)	Maximum Pick Up Voltage (V)	Minimum Drop Out Voltage (V)	Coil Nominal Voltage (VDC)	Resistance Tol.±10% (Ohms)	Nominal Current (mA)	Maximum Pick Up Voltage (V)	Minimum Drop Out Voltage (V)
12	18	9.6	3.6	6	22.5	266	4.8	0.6
24	72	19.2	7.2	12	90	133	9.6	1.2
48	288	38.4	14.4	24	360	66	19.2	2.4
110	1,512	88.0	33.0	48	1,440	33	38.4	4.8
220	6,050	176.0	66.0	120	9,000	13	96.0	12.0
240	7,200	192.0	72.0					

## CONTACT RATING

MK2PI (2PDT)	AC 250V/30VDC	10A
MK3P5I(3PDT)	AC 250V/30VDC	10A

## DIMENSIONS(±0.2mm)

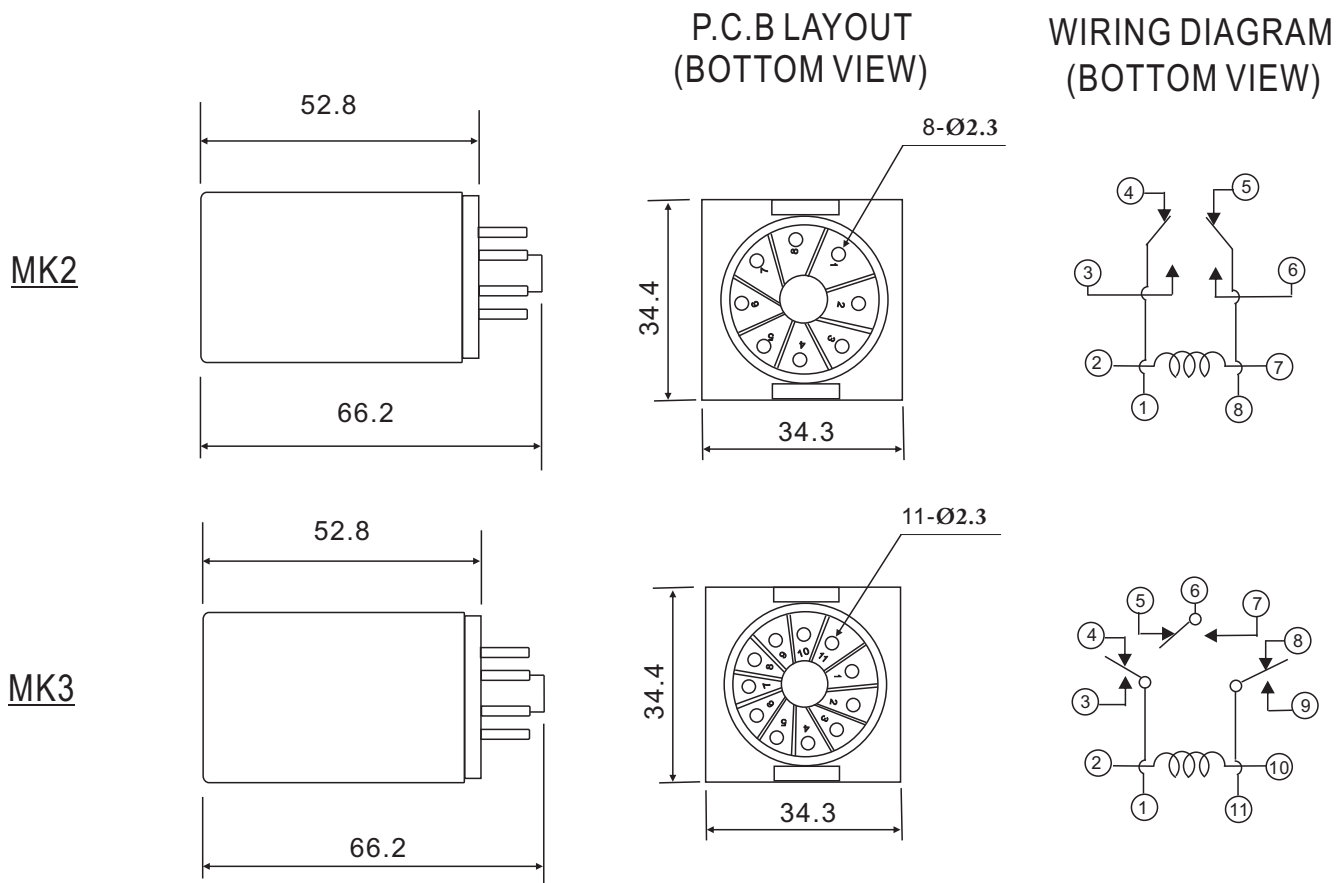

## GENERAL DATA

Insulation Resistance	500 MΩ Min. (DC 500V)
Dielectric Strength	1,000 VAC, 50/60Hz between contact.
	1,500 VAC, 50/60Hz between all elements.
Contact Material	Ag Alloy.
Contact Resistance	50 milliohms max. ( initial value )
Shock Resistance	Malfunction: 10G(11ms) ; Destructive: 100G(6ms)
Vibration Resistance	Malfunction: 10 to 55 Hz. at Double Amplitude of 1.5 mm
	Destructive: 10 to 55 Hz. at Double Amplitude of 1.5 mm
Operation Time	15 ms max.
Release Time	10 ms max.
Temperature Range	- 40°C ~ + 55°C
Expected Life	With operation rate 30/min.
	Mechanical - 10,000,000 operations min.
	Electrical - 100,000 operations min. at rated load.
Weight	MK2PI Type : 70 grams, MK3P5I Type : 80 grams

## FEATURES

- 2 Pole and 3 Pole type are available.
- Contact rating up to 40A/250VAC



## ORDERING INFORMATION

JQX38 — F 12 D

1                    2        3        4

1. Type
2. Nil: 2PDT  
F: 3PDT
3. Coil Nominal Voltage
4. Coil Nominal Voltage Type  
D: DC  
A: AC

## COIL DATA(at 25°C)

AC 4.5VA				DC 2.5W				
Coil Nominal Voltage (50/60Hz)	Resistance Tol.±10% (Ohms)	Maximum Pick Up Voltage (V)	Minimum Drop Out Voltage (V)	Coil Nominal Voltage (VDC)	Resistance Tol.±10% (Ohms)	Nominal Current (mA)	Maximum Pick Up Voltage (V)	Minimum Drop Out Voltage (V)
6	2.4	4.8	1.8	6	14	150	4.5	0.6
12	10	9.6	3.6	12	57	75	9.0	1.2
24	39	19.2	7.2	24	230	37	18.0	2.4
48	155	38.4	14.4	48	920	19	36.0	4.8
120	970	96.0	36.0	110	4,840	9	82.5	11.0
240	3,880	192.0	72.0					

## CONTACT RATING

JQX38 (2PDT)	AC 250V/30VDC	40A
JQX38F(3PDT)	AC 250V/30VDC	40A

## DIMENSIONS(±0.2mm)

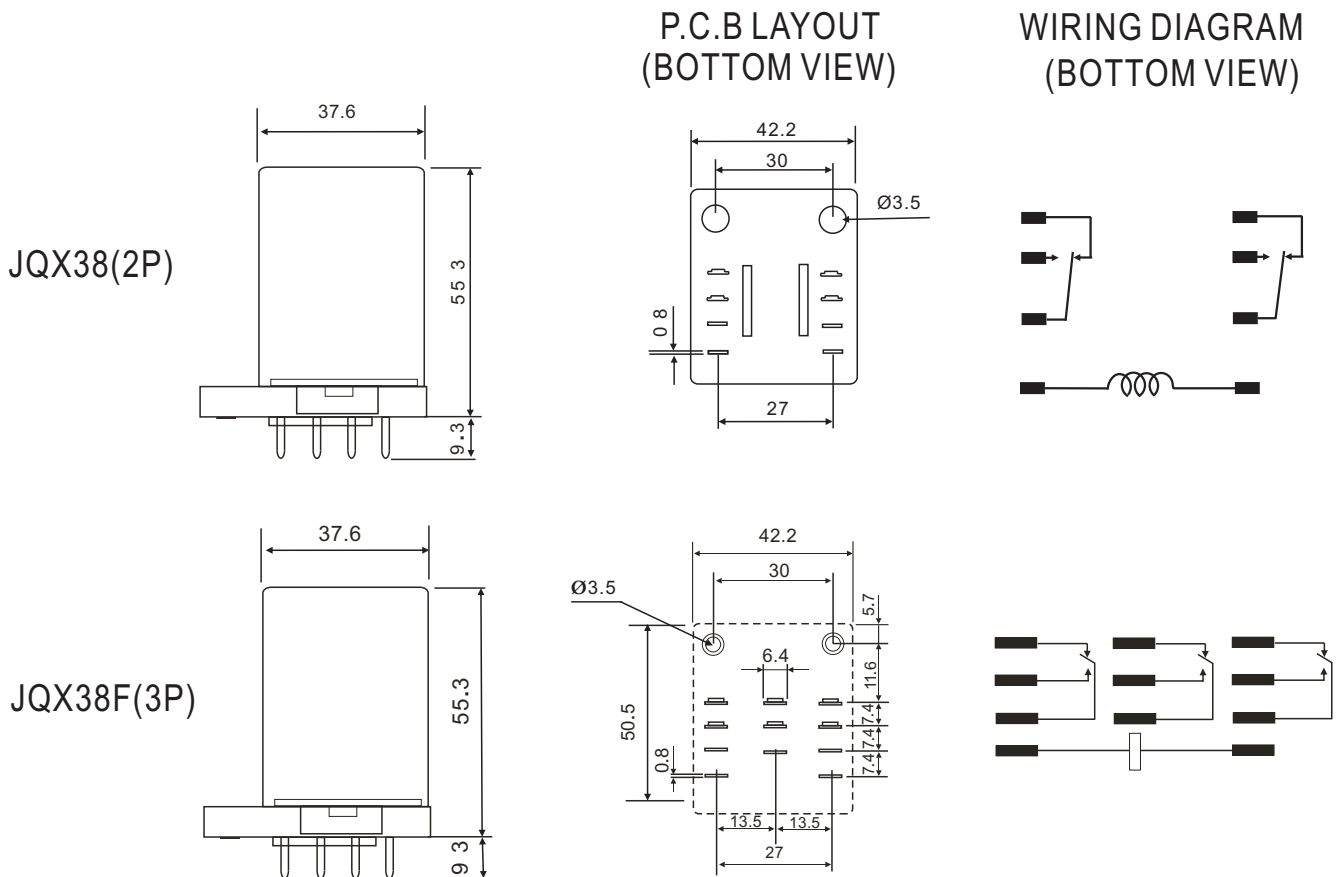

## GENERAL DATA

Insulation Resistance	100 MΩ Min. (DC 500V)
Dielectric Strength	1,000 VAC, 50/60Hz between contact.
	2,500 VAC, 50/60Hz between all elements.
Contact Material	Ag Alloy
Contact Resistance	100 milliohms max. ( initial value )
Shock Resistance	Malfunction: 10G(11ms) ; Destructive: 100G(6ms)
Vibration Resistance	Malfunction: 10 to 55 Hz. at Double Amplitude of 1.5 mm
	Destructive: 10 to 55 Hz. at Double Amplitude of 1.5 mm
Operation Time	15 ms max.
Release Time	10 ms max.
Temperature Range	- 40°C ~ + 60°C
Expected Life	With operation rate 30/min.
	Mechanical - 10,000,000 operations min.
	Electrical - 100,000 operations min. at rated load.
Weight	130 grams



## FEATURES

- 2 Pole and 3 Pole type are available.
- Contact rating up to 10A/250VAC



## ORDERING INFORMATION

JQX53 — F 12 D  
 1                      2      2      3

1. Type
2. Nil:2 PDT  
F:3 PDT
3. Coil Nominal Voltage
4. Coil Nominal Voltage Type  
D: DC  
A: AC

## COIL DATA(at 25°C)

AC 2.5VA				DC 1.2W			
Coil Nominal Voltage (50/60Hz)	Resistance Tol.±10% (Ohms)	Maximum Pick Up Voltage (V)	Minimum Drop Out Voltage (V)	Coil Nominal Voltage (VDC)	Resistance Tol.±10% (Ohms)	Maximum Pick Up Voltage (V)	Minimum Drop Out Voltage (V)
12	20	9.6	3.6	12	120	9.0	1.2
24	81	19.2	7.2	24	480	18.0	2.4
48	320	38.4	14.4	48	1920	36.0	4.8
120	2000	88.0	36.0	120	12000	82.5	11.0
220	6700	176.0	72.0				

## CONTACT RATING

JQX53 (2PDT)	AC 250V/30VDC	10A
JQX53-F(3PDT)	AC 250V/30VDC	10A

## DIMENSIONS(±0.2mm)

JQX53

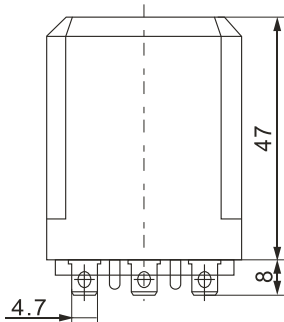

P.C.B LAYOUT  
(BOTTOM VIEW)

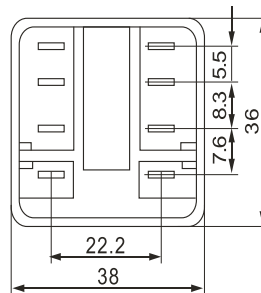

WIRING DIAGRAM  
(BOTTOM VIEW)

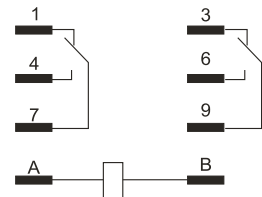

JQX53-F

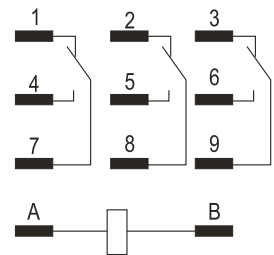
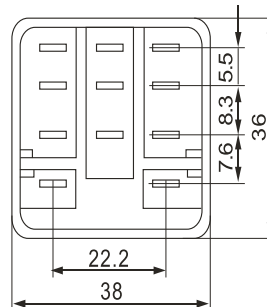
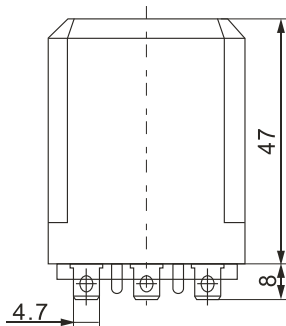

## GENERAL DATA

Insulation Resistance	1000 MΩ Min. (DC 500V)
Dielectric Strength	2,500 VAC, 50/60Hz between contact.
	1,200 VAC, 50/60Hz between all elements.
Contact Material	Ag Alloy
Contact Resistance	100 milliohms max. ( 1A 6VDC )
Shock Resistance	Malfunction: 10G(11ms) ; Destructive: 100G(6ms)
Vibration Resistance	Malfunction: 10 to 55 Hz. at Double Amplitude of 1.5 mm
	Destructive: 10 to 55 Hz. at Double Amplitude of 1.5 mm
Operation Time	15 ms max.
Release Time	10 ms max.
Temperature Range	- 40°C ~ + 60°C
Expected Life	With operation rate 30/min.
	Mechanical - 10,000,000 operations min.
	Electrical - 100,000 operations min. at rated load.
Weight	125 grams

## FEATURES

- 2 Pole type are available.
- Contact rating up to 80A/250VAC



## ORDERING INFORMATION

**JQX62 - F 12 D**

1                      2                      3                      4

1. Type
2. F:2PDT
3. Coil Nominal Voltage
4. Coil Nominal Voltage Type  
D:DC  
A:AC

## CONTACT RATING

JQX62-F(2PDT)	Resistive (Cos.θ = 1)	250V AC/30VDC	80A
---------------	-----------------------	---------------	-----

## COIL DATA( at 25°C)

AC 4.0VA				DC 2.0W			
Coil Nominal Voltage (50/60Hz)	Resistance Tol.±10% (Ohms)	Maximum Pick Up Voltage (V)	Minimum Drop Out Voltage (V)	Coil Nominal Voltage (VDC)	Resistance Tol.±10% (Ohms)	Maximum Pick Up Voltage (V)	Minimum Drop Out Voltage (V)
6	9	4.8	1.8	6	18	4.8	0.6
12	36	9.6	3.6	12	57	9.6	1.2
24	144	19.2	7.2	24	230	19.2	2.4
48	576	38.4	14.4	48	920	38.4	4.8
110	3025	88	36.0	110	4,840	88	11.0
220	12000	176	72.0				

## DIMENSIONS(±0.2mm)

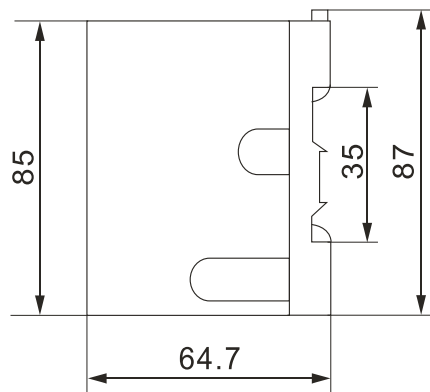
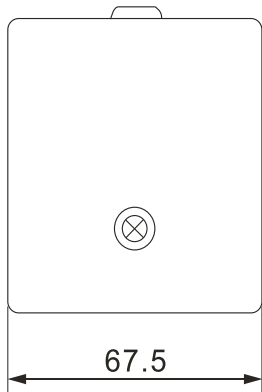

WIRING DIAGRAM  
(BOTTOM VIEW)

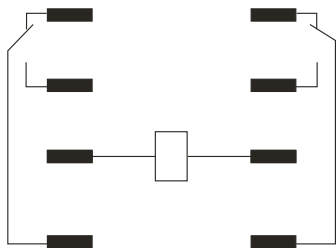

P.C.B LAYOUT  
(BOTTOM VIEW)

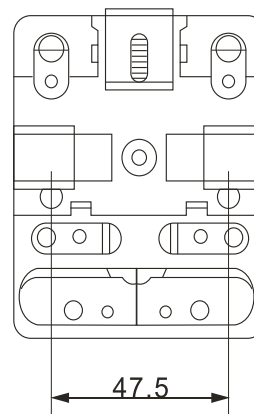

## GENERAL DATA

Insulation Resistance	1000 MΩ Min. (DC 500V)
Dielectric Strength	1200 VAC, 50/60Hz between contact.
	2500 VAC, 50/60Hz between all elements.
Contact Material	Ag Alloy.
Contact Resistance	100 milliohms max. (1A 6VDC )
Shock Resistance	Malfunction: 10G(11ms) ; Destructive: 100G(6ms)
Vibration Resistance	10Hz~500Hz Acceleration:43.1m/s <sup>2</sup>
Operation Time	40 ms max.
Release Time	25 ms max.
Temperature Range	- 40°C ~ 105°C
Expected Life	With operation rate 30/min.
	Mechanical - 10,000,000 operations min.
	Electrical - 100,000 operations min. at rated load.
Weight	4.1 grams

## J95 SERIES

### FEATURES

- Hung switching capacity: 15A.
- 1PDT, IPST
- Small SIZE, PC Board
- Plastic type, solder type
- Dimension: 19.5× 15.4×15mm
- Latching Relay

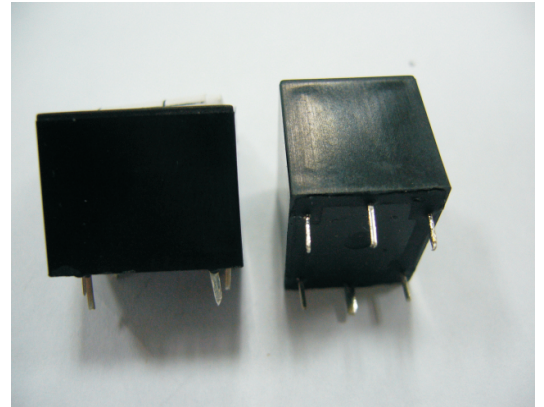

### ORDERING INFORMATION

J95    A ——— 12    S  
1            2                    3            4

1. Type
2. Contact Arrangement  
Nil: 1 Form C  
A: 1 Form A
3. Coil Nominal Voltage
4. Nil: One Coil (0.36W)  
S: Twin Coil (0.45W)

### CONTACT RATING

1 FORM A	AC 250V / 10 A	DC 28V / 10 A
1 FORM C	AC 250V / 10 A	DC 28V / 10 A

### COIL DATA(0.36W,0.45W at 25°C)

Coil Nominal Voltage (VDC)	Resistance Tol.±10% (Ohms)		Maximum Pick Up Voltage (V)	Minimum Drop Out Voltage (V)
	0.36W	0.45W		
5	70	55	3.8	0.5
6	100	80	4.5	0.6
9	225	180	6.8	0.9
12	400	320	9.0	1.2
18	900	720	13.5	1.8
24	1600	1280	18	2.4

## DIMENSIONS(±0.2mm)

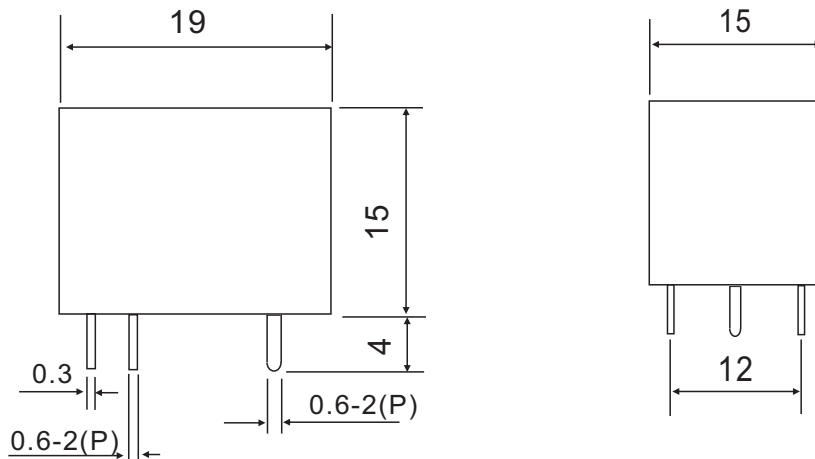

P.C.B LAYOUT  
(BOTTOM VIEW)

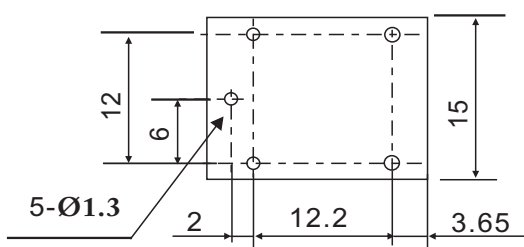

WIRING DIAGRAW

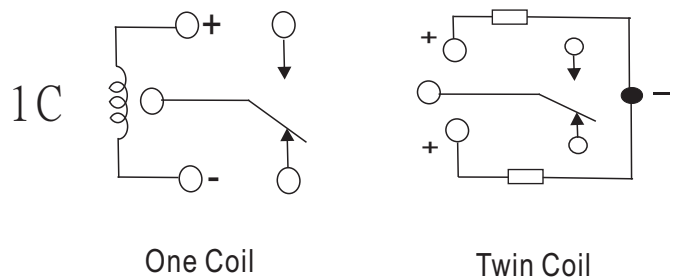

## GENERAL DATA

Insulation Resistance	1,00 MΩ Min. (DC 500V)
Dielectric Strength	750 VAC, 50/60Hz between contact.
	1,500 VAC, 50/60Hz between all elements.
Contact Material	Ag Alloy
Contact Resistance	100 milliohms max. ( initial value )
Shock Resistance	Malfunction: 10G(100m/s) ; Destructive: 100G(1000ms)
Vibration Resistance	Destructive: 10 to 55 Hz. at Double Amplitude of 1.5 mm
Operation Time	10 ms max.
Release Time	5 ms max.
Temperature Range	- 40°C ~ + 85°C
Expected Life	With operation rate 30/min.
	Mechanical - 10,000,000 operations min.
	Electrical - 100,000 operations min. at rated load.
Weight	10 grams

## J96 SERIES

### FEATURES

- Hung switching capacity: 16A.
- 1PDT, 2PDT
- Plastic type, solder type
- Dimension: 28.9× 12.6× 20.6mm

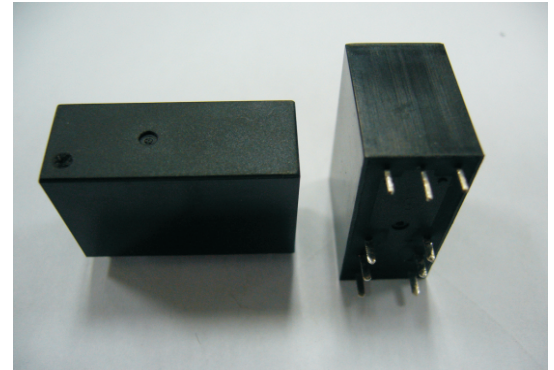

### ORDERING INFORMATION

**J96 1H A — 12 S**

1
2
3
4
5

- |                      |                        |
|----------------------|------------------------|
| 1.Type               | 3.Contact Arrangement  |
| 2.Cont.Type          | Nil: Form C            |
| 1:1 Polt             | A: Form A              |
| 2:2 Polt             | B: Form B              |
| 1H:16A(1Polt 2 Feet) | 4.Coil Nominal Voltage |
|                      | 5.NIL:One Coil(0.54W)  |
|                      | S :Twin Coil(0.72W)    |

### CONTACT RATING

J961	TYPE (1PDT)	Resistive (Cos.θ = 1)	AC 250V / DC 28V	10A
J962	TYPE (2PDT)	Resistive (Cos.θ = 1)	AC 250V / DC 28V	5A
J961H	TYPE (1PDT)	Resistive (Cos.θ = 1)	AC 250V / DC 28V	16A

### COIL DATA(0.54W,0.72W at 25°C)

Coil Nominal Voltage (VDC)	Resistance Tol.±10% (Ohms )		Maximum Pick Up Voltage (V)	Minimum Drop Out Voltage (V)
	0.54W	0.72W		
5	47	36	3.8	0.5
6	68	50	4.5	0.6
9	155	115	6.8	0.9
12	270	200	9.0	1.2
18	450	610	13.5	1.8
24	800	1100	18	2.4

## DIMENSIONS(±0.2mm)

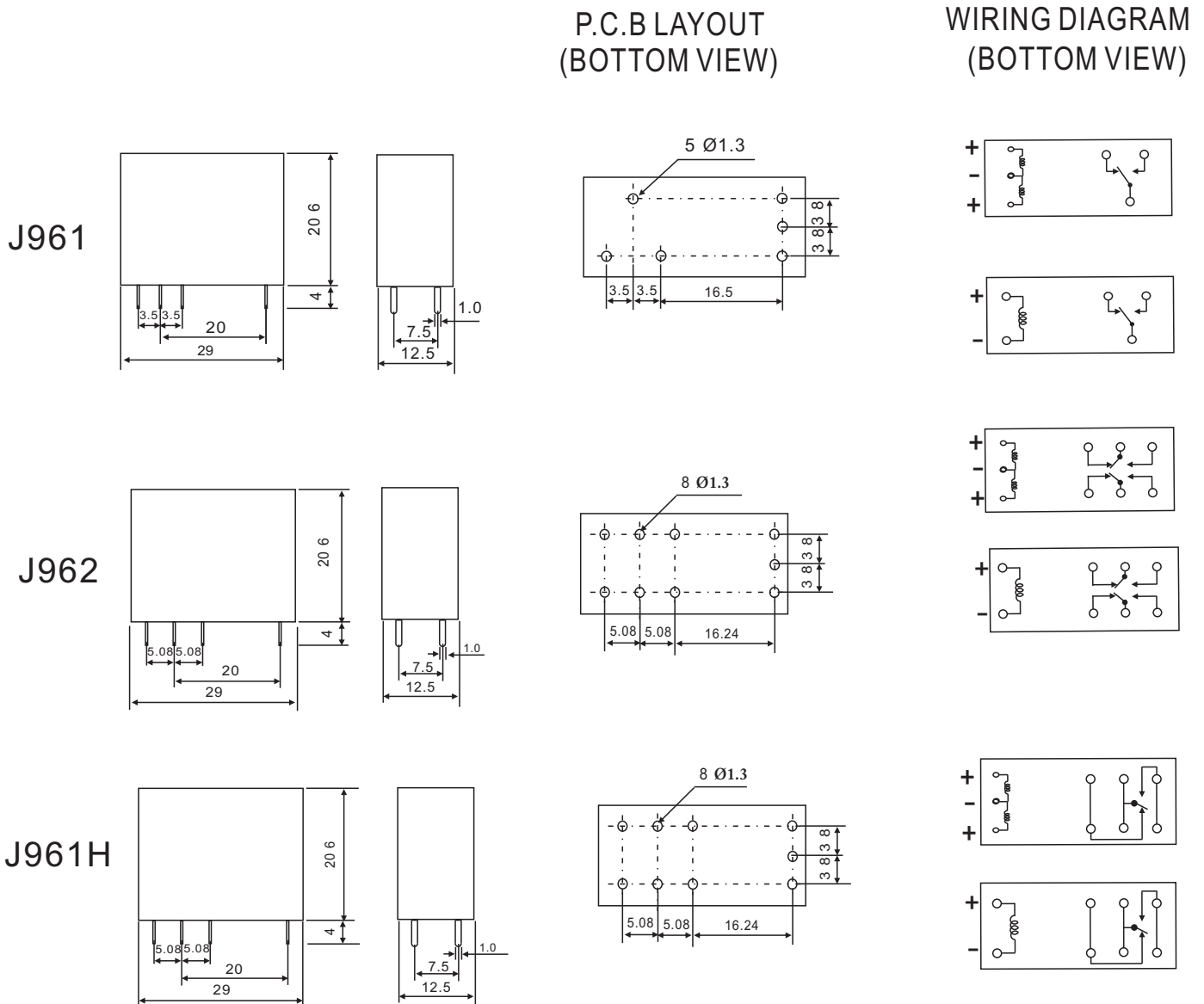

## GENERAL DATA

Insulation Resistance	1,00 MΩ Min. (DC 500V)
Dielectric Strength	750 VAC, 50/60Hz between contact.
	1,500 VAC, 50/60Hz between all elements.
Contact Material	Ag Alloy
Contact Resistance	100 milliohms max. ( initial value )
Shock Resistance	Malfunction: 10G(100m/s) ; Destructive: 100G(1000ms)
Vibration Resistance	Destructive: 10 to 55 Hz. at Double Amplitude of 1.5 mm
Operation Time	10 ms max.
Release Time	5 ms max.
Temperature Range	- 40°C ~ + 85°C
Expected Life	With operation rate 30/min. Mechanical - 10,000,000 operations min. Electrical - 100,000 operations min. at rated load.
Weight	15 grams





## DIMENSIONS: ±0.2mm

### PIN OUT 1357

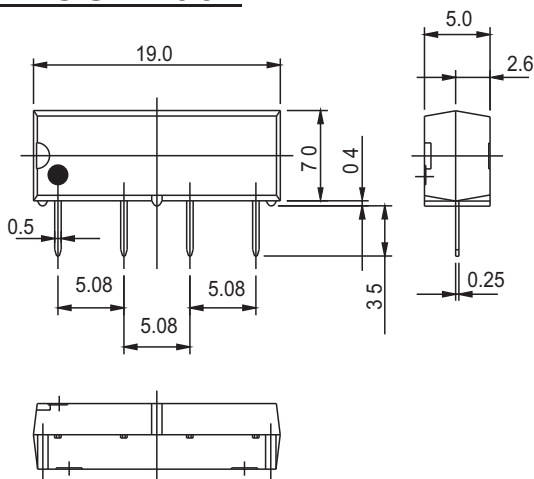

WIRING DIAGRAM  
(BOTTOM VIEW)

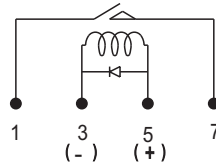

P.C.B LAYOUT  
(BOTTOM VIEW)

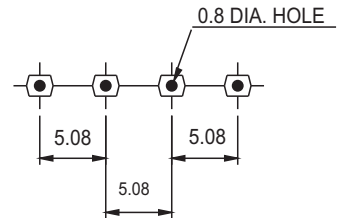

### PIN OUT 1267

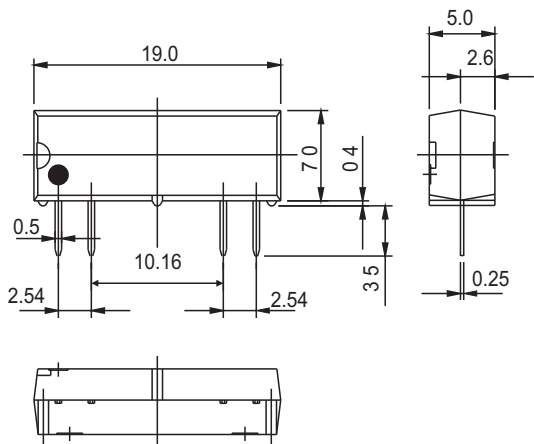

WIRING DIAGRAM  
(BOTTOM VIEW)

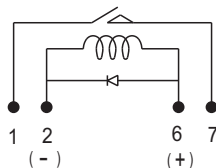

P.C.B LAYOUT  
(BOTTOM VIEW)

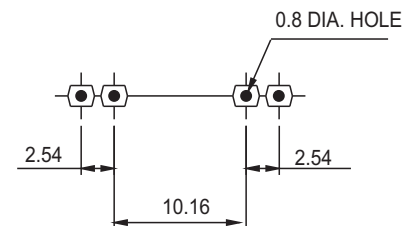

## GENERAL DATA

Insulation Resistance	1,000 MΩ Min. (DC 100V)
Dielectric Strength	250 VDC between contact.
	1,400 VDC between all elements.
Contact Material	Silver- Cadmium Oxide as standard.
Contact Resistance	150 milliohms max. ( initial value )
Switching Current	1A, 2A, 1B : 0.5ADC Max., 1C : 0.2ADC Max.
Carry Current	1A, 2A, 1B : 1.0ADC Max., 1C : 0.5ADC Max.
Switching Power	1A, 2A, 1B : 10VA Max. 1C : 3VA Max.
Operation Time	1 ms max.
Release Time	0.5 ms max.
Temperature Range	- 40°C ~ + 85°C
Expected Life	With operation rate 30/min. Mechanical - 10,000,000 operations min. Electrical - 100,000 operations min. at rated load.
Weight	1.4 grams

## FEATURES

- DIP and SMD type
- Diode version are available for customer's selection
- UL approved
- Using at security system, modem and other telecommunication products



UL FILE NO.: E126157  
CUL FILE NO.: E126157

## ORDERING INFORMATION

R2 — D 1A 05  
1                      2                      3                      4

- |                     |                         |
|---------------------|-------------------------|
| 1. Type             | 3. Contact Arrangement  |
| R2 : DIP Type       | 1A : 1 Form A(SPST-NO)  |
| R3 : SMD Type       | 1B : 1 Form B(SPSTNC)   |
| 2. Function         | 1C : 1 Form C(SPDT)     |
| Nil : Standard Type | 2A : 2 Form A(2PST-NO)  |
| D : With Diode Type | 4. Coil Nominal Voltage |
| H : High Insulation |                         |

## COIL DATA

Contact form	Nominal Voltage(VDC)	Max. Operate Voltage(VDC)	Pull in Voltage(VDC)	Dropout Voltage(VDC)	Coil ±10% Resistance(Ω)	Nominal input power(mW)
<b>1A</b>	5	16	3.75	0.8	500	50
	12	20	9.00	1.0	1000	144
	24	32	18.00	2.0	2150	268
<b>2A</b>	5	11	3.75	0.8	140	179
	12	20	9.00	1.0	500	288
	24	32	18.00	2.0	2150	268
<b>1B</b>	5	6	4.20	0.6	500	50
	12	14.5	9.00	1.0	1000	144
	24	29	18.00	2.0	2150	268
<b>1C</b>	5	11	3.75	0.8	200	125
	12	20	9.00	1.0	500	288
	24	32	18.00	2.0	2150	268

## CONTACT RATING

1PST-NO / 1PST-NC 2PST-NO	Switch Current		0.5ADC Max.	
	Carry Current		1.0ADC Max.	
1PDT	Switch Current	0.2ADC MAX.	Carry Current	0.5ADC Max.

## DIMENSIONS:±0.2mm

### DIP TYPE

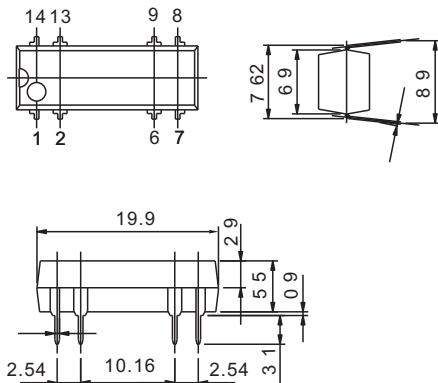

### SMD TYPE

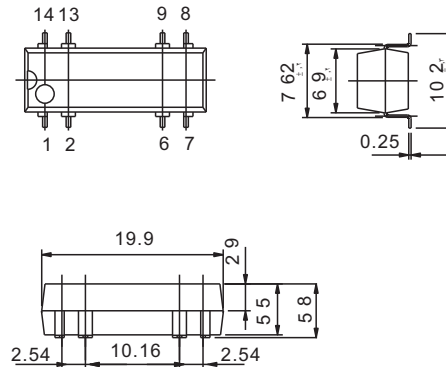

### P. C. B LAYOUT

#### DIP TYPE

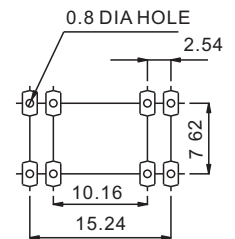

### WRING DIAGRAM

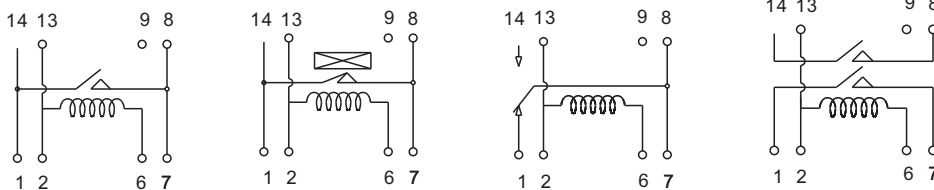

#### SMD TYPE

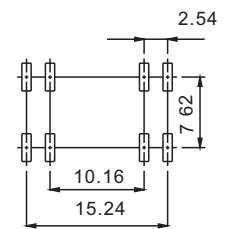

## GENERAL DATA

Insulation Resistance	1,000 MΩ Min. (DC 100V)
Dielectric Strength	250 VDC between contact.
	1,400 VDC between all elements.
Contact Material	Silver- Cadmium Oxide as standard.
Contact Resistance	150 mΩ max. ( initial value )
Switching Power	1A, 2A, 1B : 10VA Max., 1C : 3VA Max.
Carry Current	1A, 2A, 1B : 1.0ADC Max., 1C : 0.5ADC Max.
Switching Power	1A, 2A, 1B : 10VA Max. 1C : 3VA Max.
Operation Time	1.0 ms max.
Release Time	0.5 ms max.
Temperature Range	- 40°C ~ + 85°C
Expected Life	With operation rate 30/min.
	Mechanical - 10,000,000 operations min.
	Electrical - 100,000 operations min. at rated load.
Weight	1.4 grams

# R4 SERIES

## FEATURES

- Breakdown Voltage Is DC.14KV
- PCB type,pcb+wire type
- Dimensions:70×19×20.5mm
- Hingh Voltage Relay

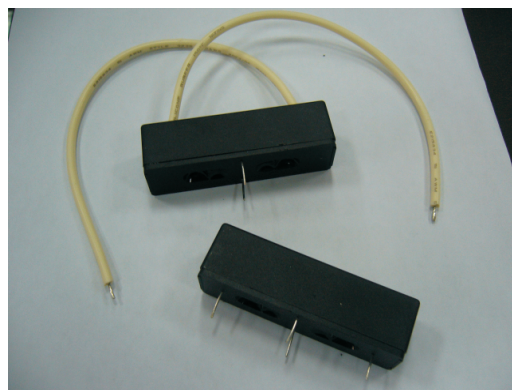

## ORDERING INFORMATION

R4 — 1A 12 W  
 1                      2                      3                      4

- |                         |                   |
|-------------------------|-------------------|
| 1. Type                 | 4. Terminals Type |
| 2.. Contact Arrangement | Nil:PCB           |
| 1A : 1 Form A           | W :PCB+Wire       |
| 1B : 1 Form B           |                   |
| 3. Coil Nominal Voltage |                   |
| DC:12V                  |                   |
| 24V                     |                   |

## CONTACT RATING

Resistive (Cos.θ = 1)	Switch Current	2.0A
	Carry Current	3.0A

## COIL DATA

Coil Nominal Voltage (VDC)	Maximum Operate Voltage(V)	Resistance Tol.±10% (Ohms)	Maximum Pick Up Voltage(V)	Minimum Drop Out Voltage (V)	Normal Current (mA)
12	15.6	200	8.4	1.2	60.0
24	31.2	720	16.8	2.4	33.3

## DIMENSIONS:±0.2mm

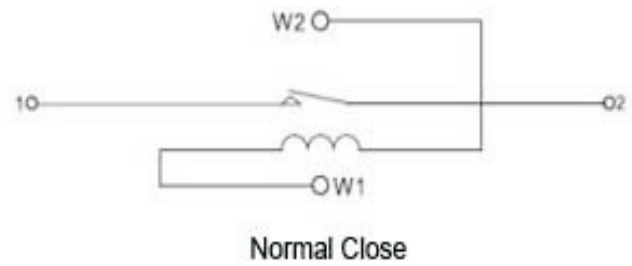
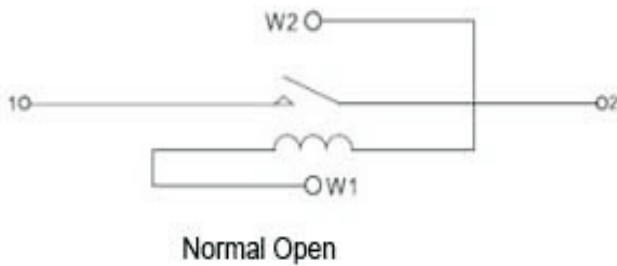
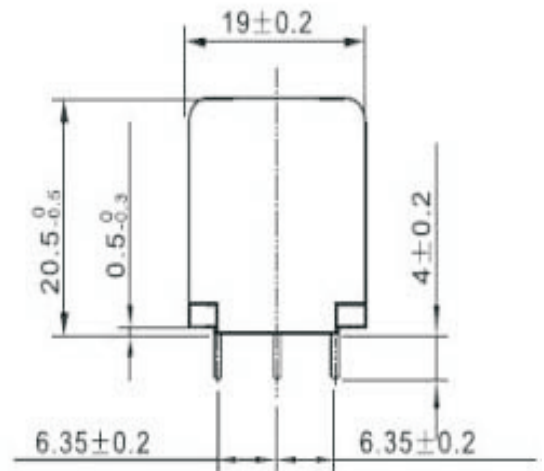
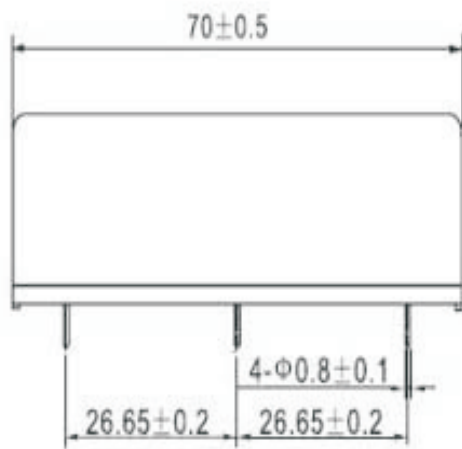

## GENERAL DATA

Contact Resistance	150 MW Max. (Inital)
Breakdown Voltage	Open Contacts DC. 14KV Min.
	Contacts to Coil DC. 15KV Min.
Insulation Resistance	Open contacts $1 \times 10^9$ W Min. (DC 100V)
	Contacts to coil $1 \times 10^9$ W Min. (DC 100V)
Electromotive Capacitance	2.0pF Max .
Operation Time	(Incl.bounce) 4.0mS Max. (at Normal Voltage)
Release Time	2.0 ms Max. (at Nomal Voltage)
Vibration	20G(0~55Hz. 1.5mm)
Shock	30G(11ms, ½ Sin Wave)
Operating Temperature	- 20°C ~ + 70°C
Storage Temperature	- 35°C ~ + 90°C
Expected Life	Mechanical - 10,000,000 operations min.
	Electrical - $1 \times 10^8$ Min Operations(R.L.)



RAYEX ELEC.

# RSR1 SERIES

## FEATURES

- Zero voltage turn-on,zero current turn-off
- Input LED indicator
- Output subber circuit protection
- TTLand CMOS compatible
- Hing dv/dt and high blocking voltage
- UL Fille No:E126157. CUL FILE No:E126157



## ORDERING INFORMATION

RSR1   N     D   —   A   240 25

          1      2      3          4      5      6

1. Series Name

2. Type Name

3. N:With LED Indicate

3:D:DC InPut Control

A: AC In Put Control

4. Out Put Nominal Voltage Type:

A: AC

D: DC

5:Out Put Nominal Voltage:

240:240V; 480:480v

6.Load Current:

10: 10Amps.

25: 25Amps.

40: 40Amps.

50: 50Amps.

型 號	DC-AC	DC-DC	AC-AC
外型尺寸(毫米)Dimension(mm)	57.4Lx44.8Wx28H	57.4Lx44.8Wx28H	57.4Lx44.8Wx28H
負載電壓(V)Load Voltage	240V,480V	24-480VDC	240V,480V
負載電流 (A)Load Current	10,25,40,50	10,25,40,50	10,25,40,50
介質耐壓 (Vac)Dielectric Strength	2500VAC	2000VAC	2500VAC
絕緣電阻 (MΩ)Insulatin Resistance	1000MΩ/500VDC	500MΩ/500VDC	1000MΩ/500VDC
控制電壓 (Vdc)Control Voltage	3~32VDC	3~32VDC	70-280VAC
控制電流 (mA)Control Current	DC3-25mA	DC5-25mA	AC≤12mA
通態壓降 (v)On Voltage Drop	≤1.5V	≤2.3V	≤1.5V
通態漏電流 (mAac)OffLeakageCurr ent	≤2mA	≤2mA	≤2mA
通斷時間 (ms)On off Time	≤10ms	≤10ms	≤10ms
動作狀態指示 Action State Indication	LED	LED	LED
環境溫度 Ambient Temperature	30°C+75°C	30°C+75°C	-30°C+75°C
安裝型式 Mounting Method	螺旋固定	螺旋固定	螺旋固定

## DIMENSIONS(±0.1mm)

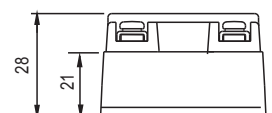
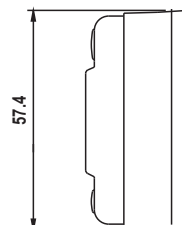
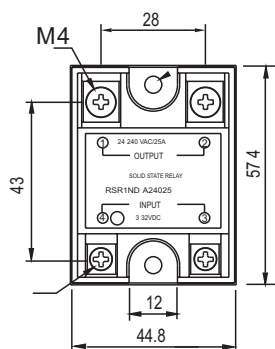

## FEATURES

- Zero voltage turn-on, zero current turn-off (minize EMI/FRI)
- Input LED indicator
- Built-in snubber network
- Low input power consumption, TTL and CMOS compatible
- High dv/dt and high blocking voltage



## ORDERING INFORMATION

RSR    2    N    D    —    A    240    03    —  
 1        2        3        3-1        4        5        6        7

- |  |  |
|--|--|
| <ol style="list-style-type: none"> <li>1. Series Name</li> <li>2. Type Name</li> <li>3. N : With LED Indicate<br/>Nil : Without LED Indicate</li> <li>3-1D : DC In Put Control</li> <li>4. Out Put Nominal Voltage Type :<br/>A : AC<br/>D : DC</li> </ol> | <ol style="list-style-type: none"> <li>5. Out Put Nominal Voltage :<br/>120 : 120V ; 240 : 240V</li> <li>6. Load Current :<br/>03 : 3 Amps.</li> <li>7. Nil : Zero-on, Normal Open<br/>R : Random-on, Normal Open</li> </ol> |
|--|--|

## DIMENSIONS(±0.2mm)

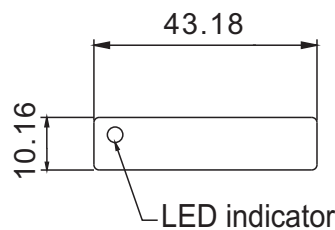
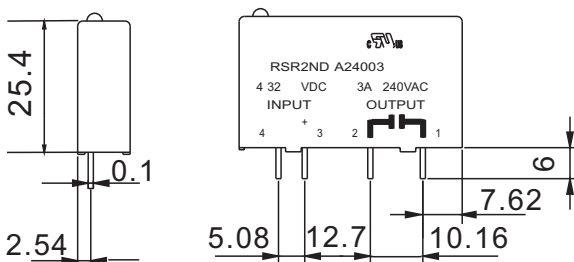

## P.C.B LAYOUT (BOTTOM VIEW)

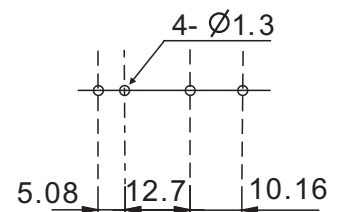





RAYEX ELEC.

# RELAY SOCKET

PT-080 Fit to LB1, LB2 SERIES

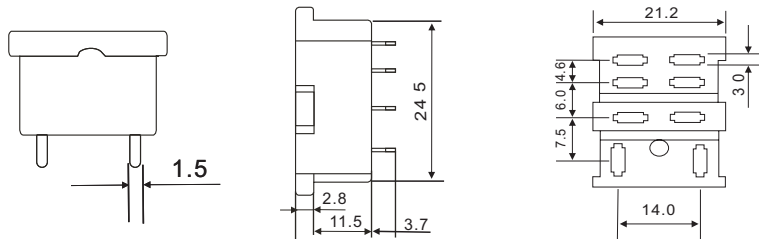
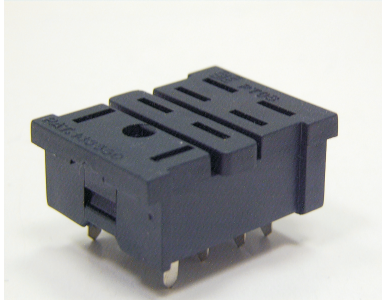

PY-080 Fit to LB2H SERIES

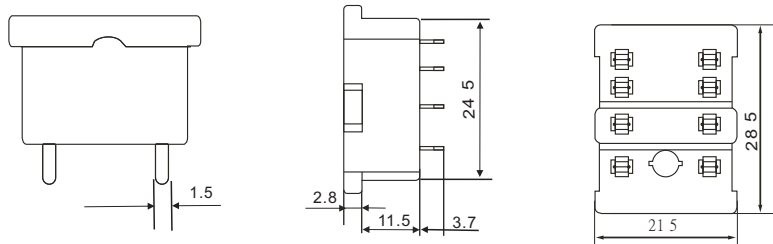
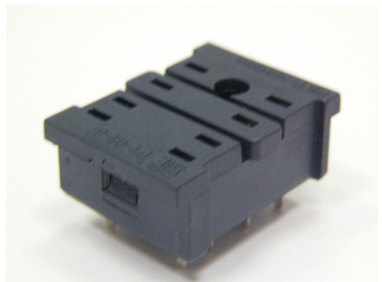

PY-140 Fit to LB4H SERIES

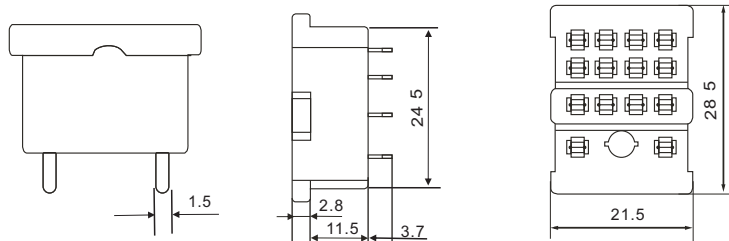
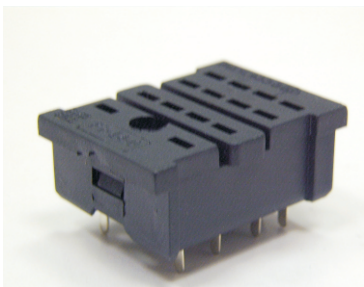



RAYEX ELEC.

# RELAY SOCKET

PTF-08A-A Fit to LB1, LB2 SERIES

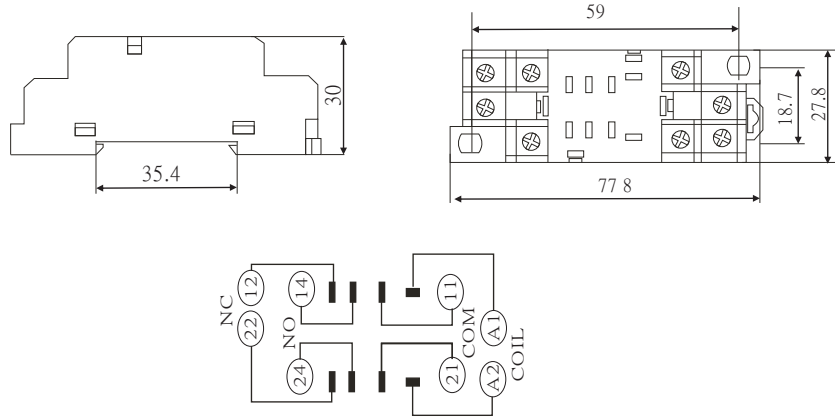
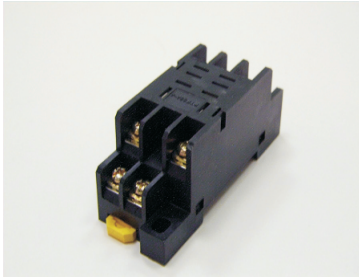

PYF-08A-A Fit to LB2H SERIES

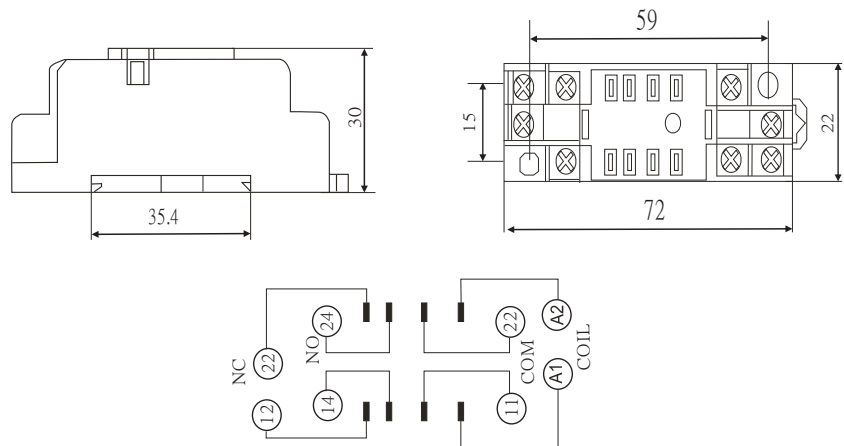
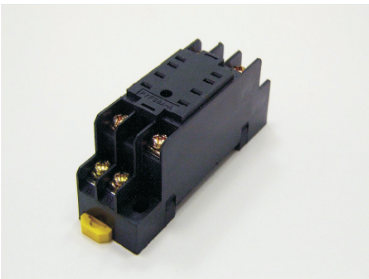

PYF-14A-A Fit to LB4H SERIES

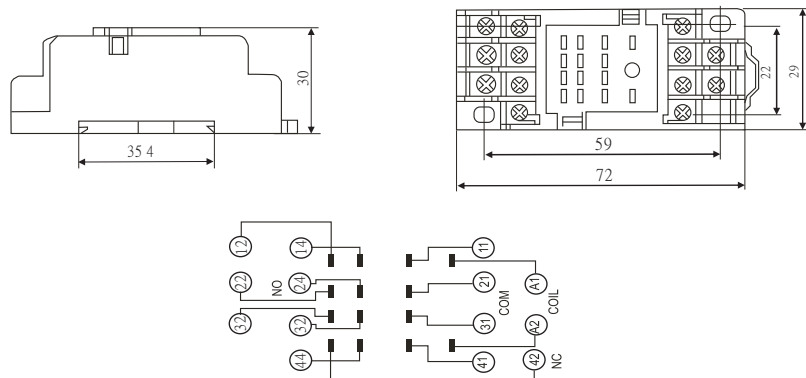

# RELAY SOCKET

PTF-08A-E Fit to LB1, LB2 SERIES

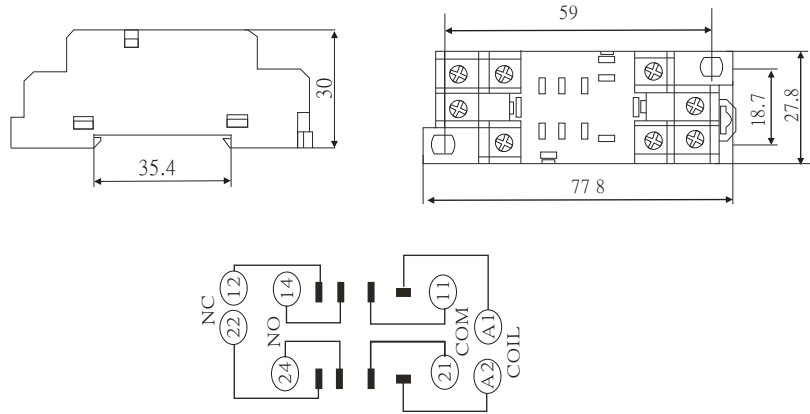
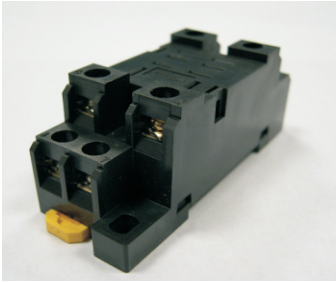

PYF-08A-E Fit to LB2H SERIES

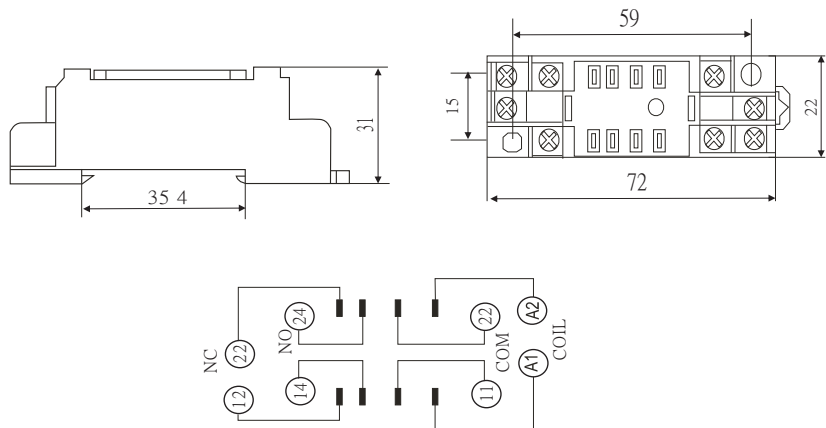

PYF-14A-E Fit to LB4H SERIES

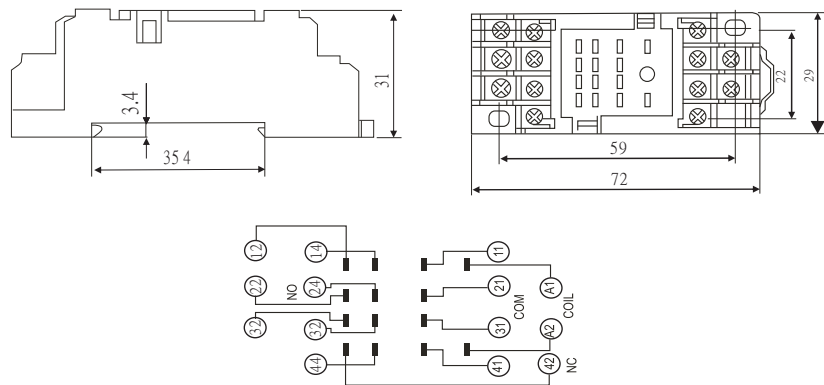

# RELAY SOCKET

RS-M01 Fit to LM1,LMR1,LMR1L

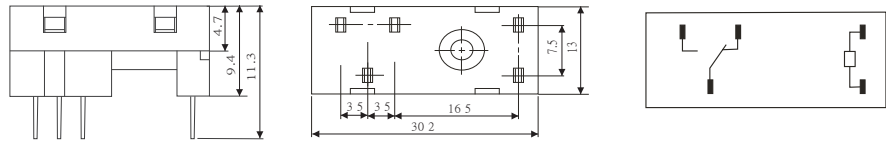
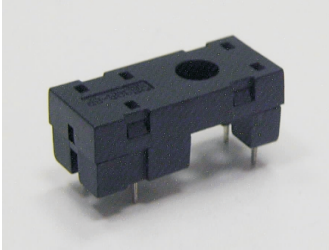

RS-M02 Fit to LM2,LMP2,LMR2,LMP1H,LM1H,LMR1H SERIES

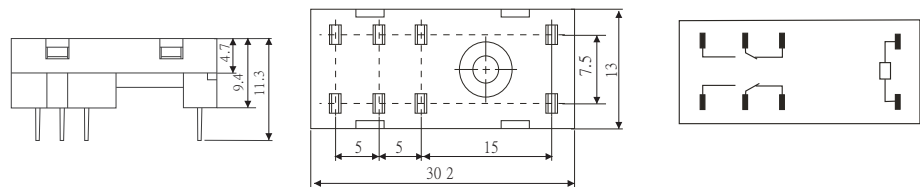
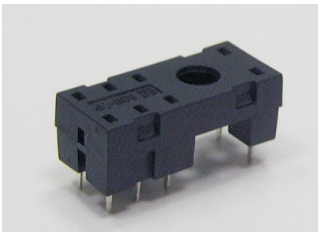

RS-M03 Fit to LM1,LMR1 SERIES

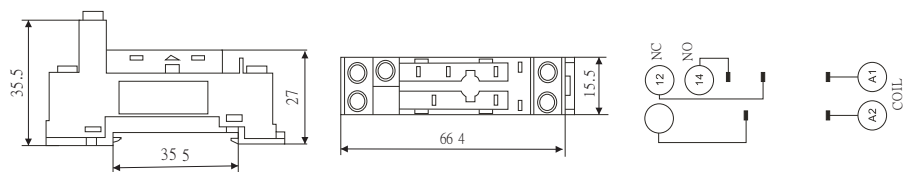
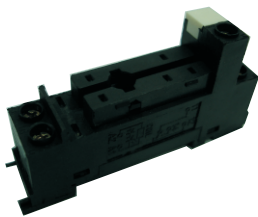

RS-M04 Fit to LM2,LMR2 SERIES

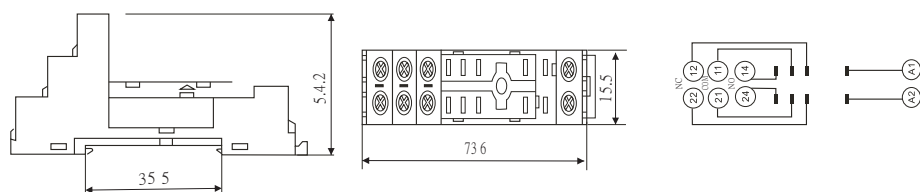
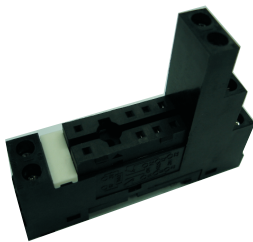

# RELAY SOCKET

## PF-083A Fit to MK2 SERIES

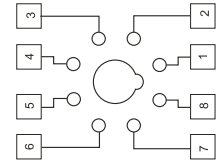
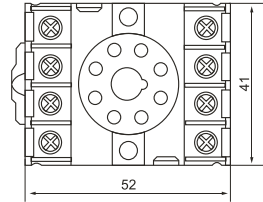
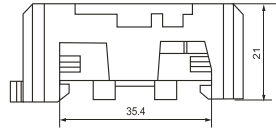

## PF-113A Fit to MK3 SERIES

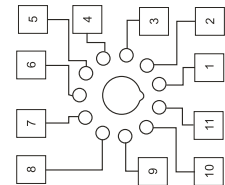
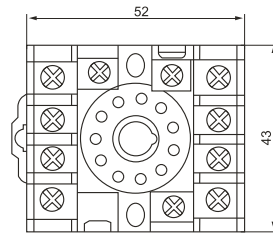
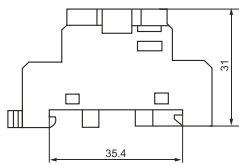

## PTF-14A Fit to LY4 SERIES

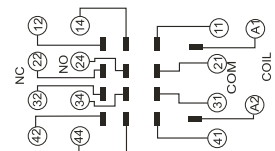
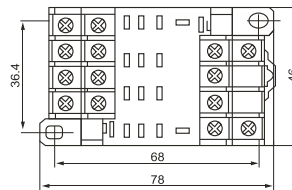
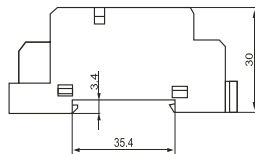

# RELAY SOCKET:

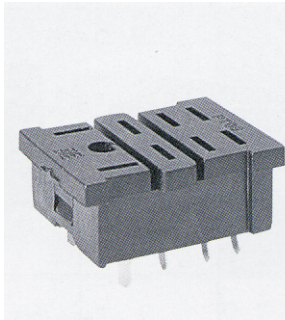

PT-080

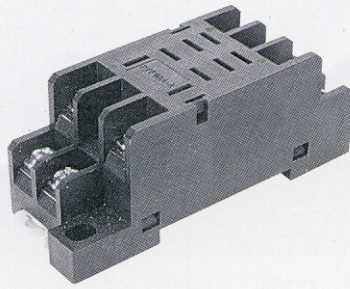

PTF-08A-A

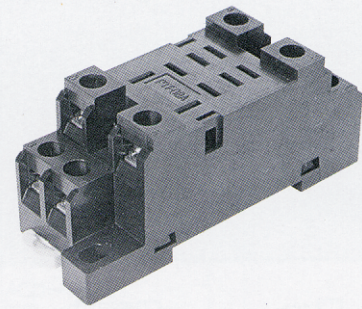

PTF-08A-E

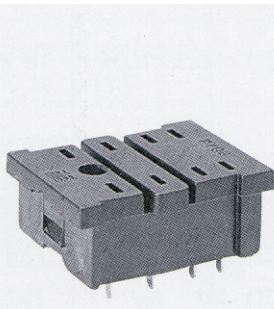

PY-080

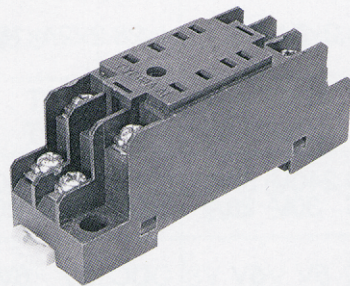

PYF-08A-A

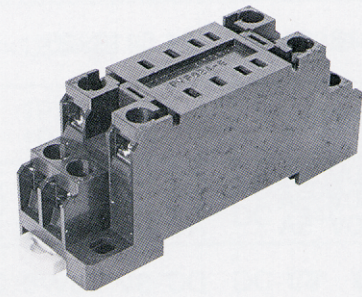

PYF-08A-E

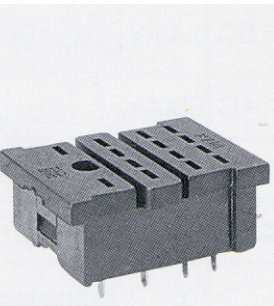

PY-140

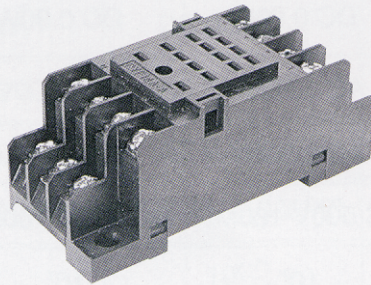

PYF-14A-A

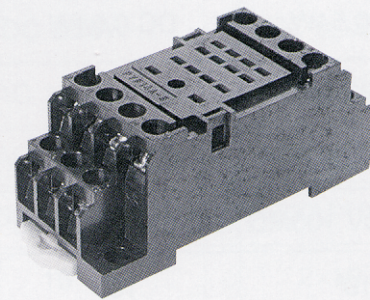

PYF-14A-E

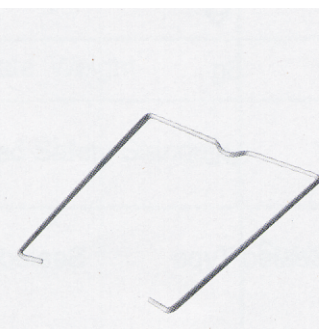

PYC-P

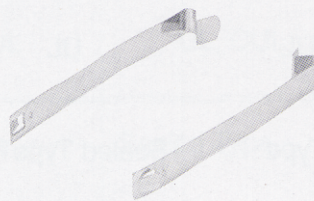

PYC-A1

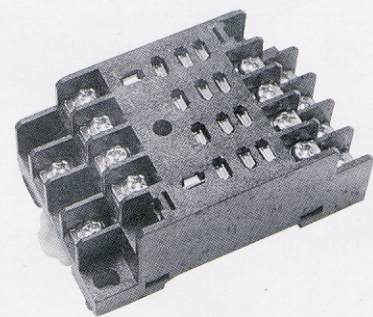

PTF-14A

# RELAY SOCKET:

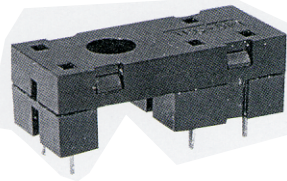

RS-M01

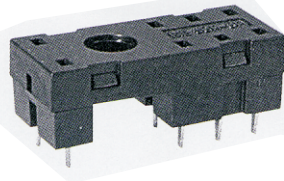

RS-M02

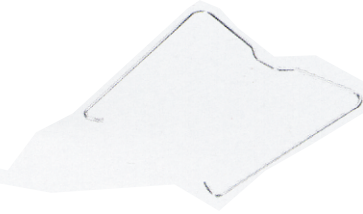

PYC-M

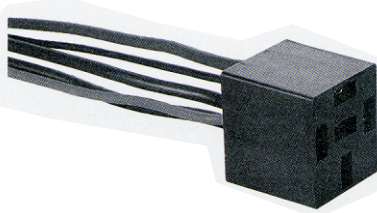

RS-D01

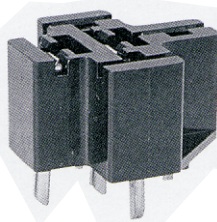

RS-D02

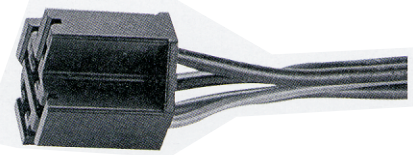

RS-D03

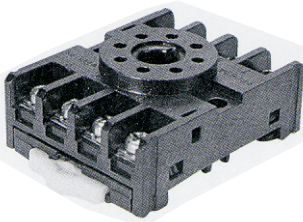

PF-083A

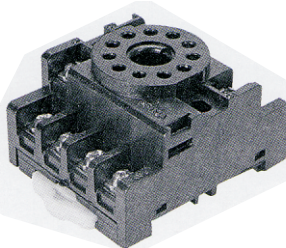

PF-113A

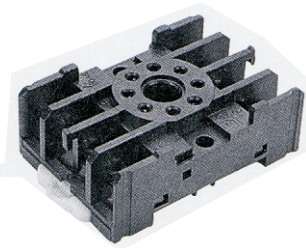

PF-085A

## RELAY & SOCKET COMPARISON LIST

Socket Relay Type	Suitable for Socket	Clip	Relay Type Socket	Suitable for Socket	Clip	Page No.
LB1 LB2	PT-080	PYC-P	LM1 LMR1	RS-M01	PYC-M	
	PTF-08A-A,FTF-08A-E	PYC-A1				
LB2H	PY-080	PYC-P	LM2,LMR2 LM1H,LMR1H	RS-M02	PYC-M	
	PYF-08A-A,PYF-08A-E	PYC-A1				
LB4H	PY-140	PYC-P	LD,LDN	RS-D01 RS-D02 RS-D03	—————	
	PYF-14A-A,PYF-14A-E	PYC-A1				

# CONTACT PROTECTIVE CIRCUIT



• **Contact Protection Circuit**

Use of contact protective devices or protection circuits can suppress the

counter emf to a low level. However, note that incorrect use will result in an

adverse effect. Typical contact protection circuits are given in the table below.

( ○ : Good   × : No Good )

Circuit	Application	Application		Features/Others	Device Selection
		AC	DC		
CR circuit		*	○	If the load is timer, leakage current flows through the CR circuit causing faulty operation. *If used with AC voltage, be sure the impedance of the load is sufficiently smaller than that of the CR circuit.	As a guide in selecting r and c, r: 0.5 to 1W per 1V contact voltage c: 0.5 to 1mF per 1A contact current Values vary depending on the properties of the load and variations in relay characteristics. Capacitor c acts to suppress the discharge the moment the contacts open. Resistor r acts to limit the current when the power is turned on the next time. Test to confirm. Use a capacitor with a breakdown voltage of 200 to 300V. Use AC type capacitors (non polarized) for AC circuits.
		○	○	If the load is a relay or solenoid, the release time lengthens. Effective when connected to both contacts if the power supply voltage is 24 or 48V and the voltage across the load is 100 to 200V.	
Diode circuit		×	○	The diode connected in parallel causes the energy stored in the coil to flow to the coil in the form of current and dissipates it as joule heat at the resistance component of the inductive load. This circuit further delays the release time compared to the CR circuit. (2 to 5 times the release time listed in the catalog)	Use a diode with a reverse breakdown voltage at least 10 times the circuit voltage and a forward current at least as large as the load current. In electronic circuits where the circuit voltages are not so high, a diode can be used with a reverse breakdown voltage of about 2 to 3 times the power supply voltage.
Diode and zener diode circuit		×	○	Effective when the release time in the diode circuit is too long.	Use a zener diode with a zener voltage about the same as the power supply voltage.
Varistor circuit		○	○	Using the stable voltage characteristics of the varistor, this circuit prevents excessively high voltages from being applied across the contacts. This circuit also slightly delays the release time. Effective when connected to both contacts if the power supply voltage is 24 or 48V and the voltage across the load is 100 to 200V	_____

Avoid using the protection circuits shown in the figures on the right. Although DC inductive loads are usually more difficult to switch than

resistive loads, use of the proper protection circuit will raise the characteristics to that for resistive loads.

Although extremely effective in arc suppression as the contacts open, the contacts are susceptible to welding since energy is stored in C when the contacts open and discharge current flows from C when the contacts close.	Although extremely effective in arc suppression as the contacts open, the contacts are susceptible to welding since charging current flows to C when the contacts close.



